

TAUBENREUTHER



■ ■ ■ ■ SUV ■ 4x4 ■ PICKUP ■ ■ ■ ■



41 years And counting ...

Taubenreuther has been in this business for over 40 years and we have a long tradition of providing quality service. We want to be the best so we study and test each item and increase our technical and practical knowledge of every article we carry. This expertise we can then pass on to our customers and we feel confident standing behind our portfolio of products. Our constant dialogue with our customers allows us to pass on our technical knowledge as well as getting very valuable feedback from many customers that we, in turn, can pass on!

Today's media, especially the internet, has brought about dramatic changes to the way business is conducted in the past decade. Information is at everyone's fingertips to allow us all to evaluate our purchases from every angle. The downside is, of course, that everyone becomes an expert and this can sometimes have disastrous consequences! We at Taubenreuther believe that our traditional working practices should work hand in hand with modern technology and our core principles can be summed up in 8 key areas:



Availability – You can have the best internet page in the world – but if you don't have the service to back it up it then it is almost useless! At Taubenreuther we still believe that business should be personal! We have a fully trained staff available to respond to you personally during normal business hours. We are just a phone call away and will answer your questions, concerns or take your orders!

Honesty – At Taubenreuther our policy is to be very clear, if we cannot answer your question immediately then we will tell you that – and then take the time to go and research it and get back to you. If there is a delay in your delivery date, we will let you know. If you can get something more suitable from another company, we will be honest enough to point you in their direction. Honesty is our best policy!

Testing – All the products available from Taubenreuther are tested by Taubenreuther and carry the necessary European certifications. We run a variety of vehicles throughout our European network and therefore we have first hand experience of their functionality and fit and because of this we can pinpoint and fix any weak points before putting them on sale. Our hands on experience benefits us when selling the merits of the product to you.



Quality – We don't just sell any product – if it doesn't pass our stringent quality control then, quite simply, we don't want it. Not only are we ISO TS 16949 quality certified but many of our suppliers are too. When needed, we obtain TUV certification and we produce simple, clear installation instructions.

Innovation – We are constantly on the look out for new and improved products throughout the world to introduce into the European market. We make sure we are up to date with the ever changing European standards so that we can be flexible and quick to offer what you need – when you need it !

Installation & Repairs – We have fully equipped workshops and trained mechanics who will undertake anything from simple repairs and installations to complete vehicle builds to your specific needs.

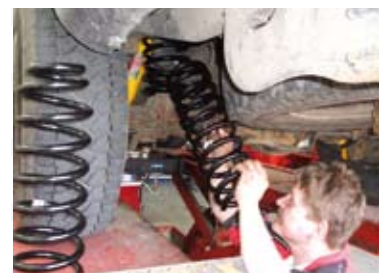

Promotion
We want the market to grow (of course!) but we want that growth to be responsible and safe to our customers. We work hard to promote the products that are worthy of the quality stamp and in order to stimulate growth in the market we make sure we carry a good supply of spare parts and accessories to keep you on the road.



Of course we want to make a profit too for our European employees and to be able to keep offering you what you need and want.

Adaptability – We want to adapt to an ever changing market but we are careful to make sure we do this without comprising any of our core principles and we never want to forget that our business is thanks to our customers – and their needs are key to our business.

We hope that you find what you want in this catalogue and that our tried and tested portfolio interests you!

See you soon!

Your
TAUBENREUTHER Team

CONTENTS



WARN winches

Pages 4 – 7



Winch accessories

Pages 8 – 13



Winch mounting systems

Pages 14 – 19



OME Suspension

Pages 20 – 23



KONI Shock absorbers

Page 24



4T Shock absorbers

Page 25



Hubs / Seats

Pages 26 – 27



Special wheels

Pages 28 – 29



Compressors / Accessories

Pages 30 – 35



ARB Diff-Lock Bumpers / Skid Plates

Pages 36 – 39



Skid Plates

Pages 40 – 41



NEWS

Pages 42 – 44



Rear Bumpers

Page 45



Roof Rack systems

Pages 46 – 50



Tents / Roof consoles

Pages 50 – 53



Drawer Systems

Pages 54 – 55



Fridges / Coolers

Pages 56 – 59



HiLift / Outdoor-Accessories

Pages 60 – 62



Tanks / Snorkel / Thule

Pages 63 – 65



Electric Accessories

Pages 66 – 69



Pickup-Accessories

Pages 70 – 79

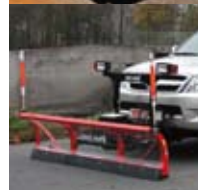

Sno-way Pages 80 – 81

Internet/Brochures Page 82

Partner Page 83



WINCHES



RT 25

RT 25 (Rugged Terrain)

This is the winch for you when you need 1133 kg of rugged pulling power using durable wire rope. This unit is great for pulling a heavy load or recovering a stuck ATV. Features include our patent-pending brake to hold you on steep inclines, a reliable all metal 3 stage planetary geartrain, an efficient electrical system that allows for longer pulls with minimal battery drain, and handlebar-mounted mini-rocker switch for great control.



- Part-Nr.: 1-75000
- Rated line pull: 1133 kg
- Motor: 0,7 kW
- Control: Mini-rocker switch with Handlebar mount
- Gear train: 3-Stage Planetary
- Gear ratio: 154:1
- Brake: automatic
- Weight: 7,1 kg
- Wire rope: 15 m x 5 mm
- Battery leads: 3,00 m
- Clutch control: Short throw

RT 40

RT 40 (Rugged Terrain).

The RT 40 has a massive 1814 kg pulling capacity and longest wire rope in the WARN Powersports winch lineup so you can pull heavier loads farther. This winch has tons of standard features including a patent-pending disc break that securely holds the heaviest loads, a fully sealed drivetrain to guard against the elements. A strong motor with 1,1 kW and 16,8 m x 5,5 mm together with the easy free spool clutch, the corded remote control and mini-rocker switch completing this power package.



- Part-Nr.: 1-77000
- Rated line pull: 1814 kg
- Motor: 1,1 kW
- Control: Corded Remote and mini-rocker Switch
- Gear train: 3-Stage Planetary
- Gear ratio: 136:1
- Brake: automatic
- Weight: 9,1 kg
- Wire rope: 16,8 m x 5,5 mm
- Battery leads: 3,00 m
- Clutch control: Short throw



CE-M8000 12 V / 24 V

Part-Nr.: 1-265024 (12 V)
 Part-Nr.: 1-265034 (24 V)
 Rated line pull: 3600 kg
 Motor: 3,5 kW by 12 V
 1,55 kW by 24 V
 Control: Remote switch, 3,7 m (12') lead

Gear train: 3-Stage Planetary
 Gear ratio: 216:1
 Brake: automatic
 Drum diameter: 226,5 x 63,5 mm
 Weight: 34 kg
 Wire rope: 30 m x 8 mm
 Battery leads: 1,83 m

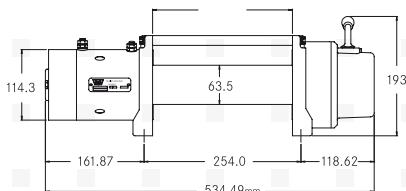

Dimensions (l x t x h)
 534 x 160 x 193 mm
 Hole-pattern 254 x 114,3 mm

Line pull in kg	Line speed m/min		Motor Current Amp	
	12 V	24 V	12 V	24 V
0	12,8	8,3	80	46
900	4,9	5,2	198	99
1800	3,6	3,8	285	145
3600	2,4	2,7	435	235

CE-M8274 12 V / 24 V

Part-Nr.: 1-386314 (12 V)
 1-375834 (24 V)
 Rated line pull: 3600 kg
 Motor: 3,4 kW by 12 V
 1,85 kW by 24 V
 Control: Remote switch, 3,7 m (12') lead

Gear train: Spur gear
 Gear ratio: 134:1
 Brake: automatic, disk type
 Drum diameter: 220 x 90 mm
 Weight: 50 kg
 Wire rope: 45 m x 8 mm
 Battery leads: 1,83 m

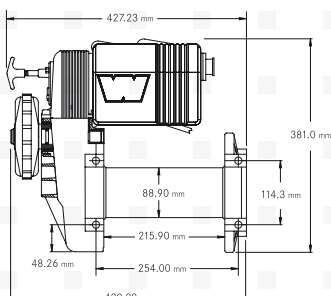

Dimensions (l x t x h)
 420 x 220 x 381 mm
 Hole-pattern 254 x 114,3 mm

Line pull in kg	Line speed m/min		Motor Current Amp	
	12 V	24 V	12 V	24 V
0	22,0	19,8	55	24
900	6,7	7,0	190	97
2700	2,9	4,0	350	203
3600	1,9	2,4	450	273

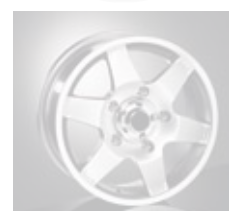
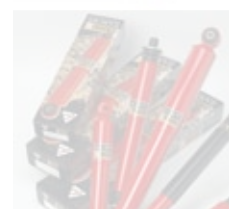
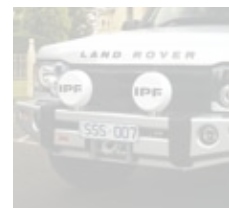



WINCHES



CE-XD9000i 12 V

Part-Nr.: 1-275504 (12 V)
 Rated line pull: 4100 kg
 Motor: 3,4 kW by 12 V
 Control: Remote switch, 3,7 m (12') lead

Gear train: 3-Stage Planetary
 Gear ratio: 156:1
 Brake: automatic
 Drum diameter: 226,5 x 63,5 mm
 Weight: 38,5 kg
 Wire rope: 38 m x 8 mm
 Battery leads: 1,83 m

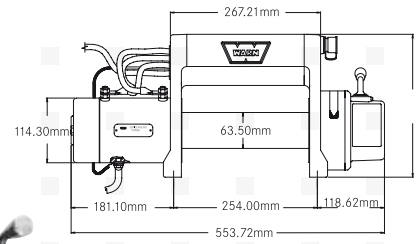

Dimensions (l x t x h)
 553 x 160 x 252 mm
 Hole-pattern 254 x 114,3 mm

WARN XDC 12 V

The new WARN XDC is an absolute classic that arouses great interest. It has a compact flat design and can therefore be used in our winch mounting kits. The motor has a thermal protection switch that protects the winch from overheating and switches it off if the temperature is too high. The sealed feet and cable drum provide additional protection against water and dirt. The contactor is also sealed against water ingress. The high gloss powder coating provides outstanding corrosion protection. An LED lamp is integrated into the 3.7 m cable remote control unit.

Fits all mounting kits.

Part-Nr.: 1-74700

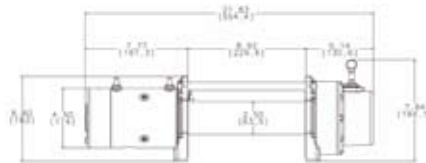

Technical data:

Rated line pull:	4.310 kg
Line speed with no load:	8,8 m/min.
Motor:	12 V 3,4 kW
Gear train:	3-Stage Planetary
Brake:	automatic cone brake
Cable:	30 m x 8 mm





Integrated solenoid

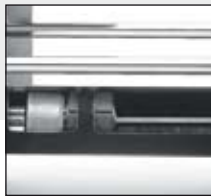

Automatic Brake



3-stage planetary gear

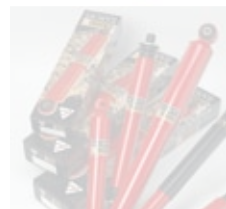

CE-M12000 12 V / 24 V

- Part-Nr.: 1-178014 (12 V)
1-265074 (24 V)
Rated line pull: 5400 kg
Motor: 3,4 kW by 12 V
1,85 kW by 24 V
Control: Remote switch, 3,7 m (12') lead
Gear train: 3-Stage Planetary
Gear ratio: 261:1
Brake: automatic
Drum diameter: 226,5 x 90 mm
Weight: 62 kg
Wire rope: 38 m x 10 mm
Battery leads: 1,83 m



Performance specifications

Line pull in kg	Line speed m/min		Motor Current Amp	
	12 V	24 V	12 V	24 V
0	9,2	9,6	67	24
1800	2,6	2,9	210	129
3600	1,8	2,3	320	175
5400	1,2	1,8	440	220

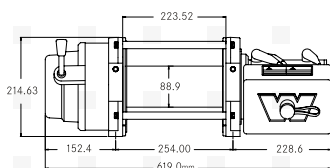

Dimensions (l x t x h)
556 x 215 x 279 mm
Hole-pattern 254 x 114,3 mm

CE-16.5 ti 12 V

- Part-Nr.: 1-68801
Rated line pull: 7480 kg
Motor: 3,4 kW
Control: Remote switch, 3,7 m (12') lead
Gear train: 3-Stage Planetary
Gear ratio: 315:1
Brake: automatic
Drum diameter: 226,5 x 90 mm
Weight: 63 kg
Wire rope: 27 m x 11 mm
Battery leads: 1,83 m



Performance specifications

Line pull in kg	Line speed m/min	Motor Current Amp
0	7,2	68
900	3,7	138
2700	2,25	240
3600	1,85	291
5400	1,34	393
7480	1,0	507

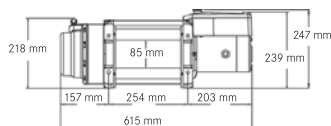

Hole-pattern 254 x 114,3 mm



Twice as smart! WARN PowerPlant: a winch and compressor in one unit

The WARN Powerplant models bring two units together in one housing: each PowerPlant is in fact both a powerful cable winch and a heavy-duty compressor.

Depending on the task required, the user can simply select between the two functions using the switchover lever.

In parallel to the launch of this unit an extensive package of accessories are also being offered. The first of these is called the "upgrade kit", which alongside an 8 m long air hose also includes a 30 cm tyre filling hose with pressure gauge (with psi display), as well as four tyre pressure reducers in a strong nylon pouch. If larger quantities of air are required, for compressed air tools, for example, we recommend the air tank either a 9.5 or 19 litres. And there is also a connection kit to connect this tank with the PowerPlant.

Part-Nr.: 1-71800 PowerPlant HP, 4.300 kg

Part-Nr.: 1-71801 PowerPlant HD, 5.400 kg

Accessories:

Part-Nr.: 1-73945 Upgradekit

Part-Nr.: 1-73938 Air tank 9,5 litres

Part-Nr.: 1-73939 Air tank 19 litres

Part-Nr.: 1-73940 Connection kit



Technical data for the compressor:

Fittings: Integrated cooler, 8 m air hose, pressure switch, pressure gauge, valve connections

Max. pressure: 7 bar

Delivery volume: 360 litres per min. at 0,6 bar
140 litres per min. at 6,0 bar

Technical data for the cable winch:

Fittings: Roller guide for cable, steel cable with hook, 3,7 m remote operating using a thermal signal

Rated line pull: 4300 kg (5400 kg)

Motor: 3,4 kW with thermal switch

Cable: 38 m x 8 mm (28 m x 9,5 mm)

Gear ratio: 156:1 (261:1)

Line speed: 1,6 m/min. to 8,2 m/min.



DYNATEC Plastic-hurry



Part-Nr.: 10-118530, 30 m x 9 mm

Part-Nr.: 10-118538, 38 m x 9 mm



Part-Nr.: 10-118550, 50 m x 9 mm

Even the 2-component rope of WARN had a common and dangerous weakness shared with others: when using the rope on hoists with a brake, and all commercial rope hoists are used in this way – when integrated in the drum they could not withstand a thermal load of over 135°.

The 1 component rope, when tested, began to rapidly degrade at 70°C. A steel cable is substantially better at withstanding high temperatures.

The use of plastic hurries, even though they provide a high level of heat resistance, contribute to the high temperatures in the drum.

From these tests the DYNATEC 2-component rope 38 m x 9 mm was developed, the first 5,5 m of which consists of a high temperature-stable fibre, which is unfortunately also very expensive. The remaining metres consist of a highly flexible and friction resistant fibre making it a good, useable cable for modern hoists

The WARN M8274 rope hoist also comes with a 50 m long 1 component rope, 9 mm in diameter. This is necessary because this model does not have a brake in the drum.

The advantages overview: security

- almost no "whip effect" if it tears
- less risk of injury, with no individual wires to break
- high breaking load of 9 t
- high corrosion protection

handling

- substantially more flexible
- lighter
- floats in the water
- easier to throw

weight

- much lighter than steel cable, able to Oroll up to 17,5 kg



Safety-Hook

Part-Nr.: 10-28626



Alu Hawse Fairlead

Part-Nr.: 10-7609



O-Shackles

The clevis O-shackle provides a means for connection of the looped ends of cables, straps and snatch blocks. The shackles pin is threaded to allow easy removal.

Part-Nr.: 10-330063,

O-shackles 2 t, breaking strength 8 t.

Part-Nr.: 10-330073,

O-shackles 3,25 t, breaking strength 13 t.

Part-Nr.: 10-330083,

O-shackles 4,75 t, breaking strength 19 t.

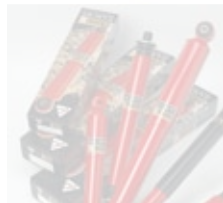



Accessories for the pro's

These original WARN accessories are designed for the hardest off road use. With this equipment you are kind to nature. The snatch block doubles the pulling power of any winch, or aids in angled pulls. Roller Fairlead reduces cable wear especially on Pulls at severe angles.



Part-Nr.: 1-25300
contains: snatch block, tree trunk protector (5 cm x 2,4 m), shackle, choker chain, gloves



Part-Nr.: 1-62858
contains: snatch block, tree trunk protector (10 cm x 2,4 m), recovery strap (8 cm x 9 m), 2 shackles, gloves

Heavy Duty Snatch Blocks

Used properly, the multi-purpose snatch block can double the pulling power of any winch, or change your pulling direction without damaging the wire rope. They also help to reduce heat build up and amp draw.

Part-Nr.: 1-63490, greasable, 13000 kg breaking strength, up to 12 mm wire rope.

Part-Nr.: 1-61560, greasable, 8600 kg breaking strength, up to 8mm wire rope



Part-Nr.:
1-63490

Part-Nr.:
1-61560

Electric plug, 175 A

Quick connect plugs

Part-Nr.: 1-22680,
(1 unit)



↓ **Multimount only available in the German version.** ↓



NEW!



WARN remote control

The new WARN remote control works on all WARN winches with 5 pin Socket. Simple to mount and extremely resistant in wet or muddy conditions. Working range is approximately 35m, with LED lights. Also shows battery level and has an on/off switch.

Part-Nr.: 1-74501



Radio Remote (FTZ + CE tested)

2-channel (standard)

Part-Nr.: 15-5522

3-channel (+ 1 additional function)

Part-Nr.: 15-5530

4-channel (+ 2 additional functions)

Part-Nr.: 15-5500



Plastic cover for roller fair lead



Roller Fairlead

Reduces wire rope wear, especially on pulls at severe angles. Zinc plated finish.

Dimensions: 29,5 x 8,5 x 12,7 cm

Part-Nr.: 1-5742 galvanized, for M6000 to M12000

Part-Nr.: 1-61956 Heavy Duty



Hawse Fairlead

The hawse fairlead is designed to guide the wire rope to and from the winch drum. Part-Nr.: 1-73850 black finish for M6000 - CE-16.5 ti

Plastic cover for roller fair lead

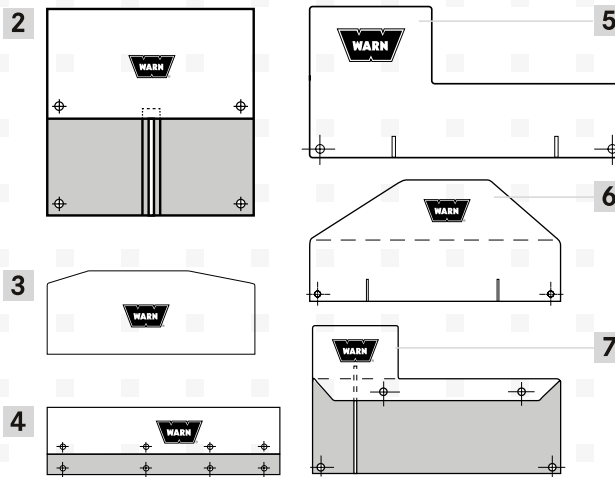

No.	Description	Part-Nr.:
1	Cover, plastic, for X9000i/8000i	1-34035
2	Cover, soft, for 8274/50	1-8557
3	Cover, soft, for M12000-16,5Ti	1-15639
4	Cover, soft, for M5000 - XD9000+9.5XP (solenoid box mounted separately)	1-18250
5	Cover, soft, for M5000 - XD9000+9.5XP (solenoid box mounted above winch motor)	1-13916
6	Cover, soft, for M5000 - XD9000i+9.5Ti/Si (solenoid box mounted above the winch drum on "i"-winches)	1-13917
7	Cover, soft, for M5000 - XD9000+9.5XP (solenoid box mounted above winch motor and high mounting plate, for example on Bumper system)	1-13918
8	Cover, neoprene for Power Plant (without picture)	1-74902
9	Cover, neoprene for 9.5 ti and 9.5 si (without picture)	1-74901

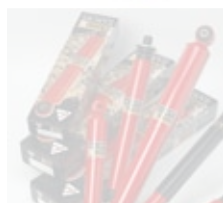

Winch Accessories

These winch accessories, manufactured by ARB in Australia, are made to withstand the toughest use to work alongside Warn products for maximum performance.



Snatch Block

6-12 mm, greasable, breaking strength 14,5 t. Part-Nr.: 35-ARB209



← Snatch Block

Rope 8-13 mm, breaking strength 17,5 t, extra light only 2,4 kg, not greasable
Part-Nr.: 35-ARB10100020



ARB Ground Anchors

Without a suitable anchor point, a winch is all but useless. As such, a ground anchor like the Portable Rescue Tree is a worthwhile investment. Employed by a number of Australian emergency services, the PRT weighs just 14 kg, can easily be carried over distance, and folds away neatly for storage.
Part-Nr.: 35-ARB230

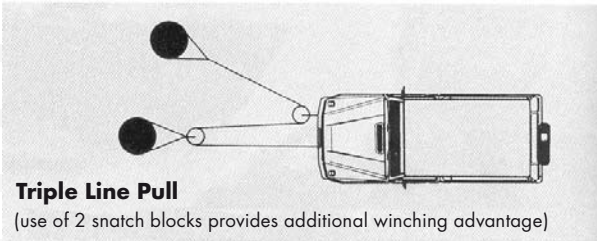
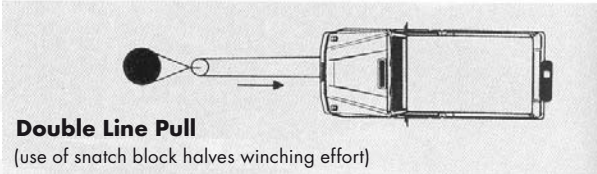
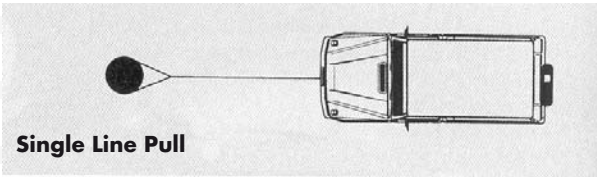



Winch Cable Dampers

While winch cables sold by ARB are exceptionally strong, safety precautions must be observed to avoid injury in the event of cable failure. Manufactured from heavy duty vinyl, an ARB winch cable damper will absorb most of the recoil in the unlikely event of the cable breaking. Part-Nr.: 35-ARB219



ARB Winch Pack

ARB's Winch Pack is designed to fit a complete recovery kit. Part-Nr.: 35-ARB501



Tree Trunk Protector

3 m x 75 mm, Breaking strength 12 t
Part-Nr.: 35-ARB730
5 m x 75 mm, Breaking strength 12 t
Part-Nr.: 35-ARB735



Towhooks

Universal towhooks to mount on the vehicle with safety latch.
Part-Nr.: 35-6125 chrome
Part-Nr.: 35-6126 black



ARB Snatch Pack

The Snatch Pack is a multi purpose bag that will suit a variety of equipment. Part-Nr.: 35-ARB502



ARB Snatch Strap

20% Elasticity
9 m x 60 mm, Breaking strength 8 t
Part-Nr.: 35-ARB705
9 m x 83 mm, Breaking strength 11 t
Part-Nr.: 35-ARB710
9 m x 110 mm, Breaking strength 15 t
Part-Nr.: 35-ARB715



Black Snake Snatch Strap

ARB is delighted to launch a new product that will appeal to customers wanting the ultimate recovery strap. The material used to make the Black Snake is traditionally used in industrial, shipping and mining applications. Comprised of high strength, nylon wound inner strands encased in a super tough vulcanised rubber sheath, the Black Snake offers vastly superior abrasion resistance compared to normal woven straps. The strap is 10 meters long, has a breaking strain of 8000 kgs and supplied with a handy storage strap for convenient stowage. Part-Nr.: 35-ARBBSS10



Tree Trunk Protector

20 m x 55 mm, Breaking strength 4,5 t
Part-Nr.: 35-ARB720
20 m x 80 mm, Breaking strength 8 t
Part-Nr.: 35-ARB725

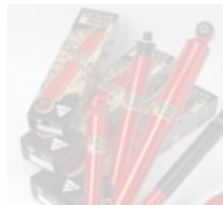



Isuzu



Discovery III

Hidden-System

This system allows you to use the winch with the original bumper so as not to change the image of the vehicle too much. Another advantage is that most OE and aftermarket bumper bars can be combined with the mounting kit. The kits are TÜV certified and when necessary also equipped with a roller fairlead cover.

Mounting time approximately 6 hours.

For Warn winches CE M6000-CD XD9000



Wrangler





Kia Sorrento



Cherokee KJ



Mercedes



Bumper mount system

The winch is visible on the bumper and the mounting kit is connected to the vehicle frame. The roller fairlead can be screwed to the mounting kit.

The winch is very visible and we obtain TÜV certification for these kits. A winch cover is used for protection of the winch from dirt and damage. Check your front axle weight – you may need to upgrade your suspension system when using the winch.

Mounting time: 6 hours.

CE M6000 - CE 9.5.

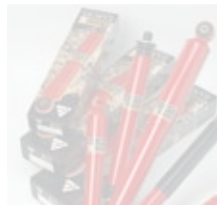

How we build a mounting kit ...



1. We look for strong mounting points ...
2. This tells us what kind of mounting system we need to use ...
3. We check if the airbag sensors will affect the mounting kit ...
4. We check which type of winch will fit ...
5. We verify where we can mount the solenoid box ...



10. We obtain TÜV certification ...
11. The prototype is released ... or not ...
12. A parts list is created ...
13. The first mounting kit from the manufactured series is re-tested on the vehicle ...



6. We check the necessary length of the solenoid cable ...
7. We check if we need to change the position of the remote receiver ...
8. We fit the first prototype to the vehicle ...
9. We make tests with the winch pulling at extreme rates and angles vertically and horizontally ...



14. Installation instructions written and photographs taken ...
15. Packaging fabricated ...
16. Catalogue and price lists created ...
17. Stocked in warehouse ...
18. Ready for delivery to our customers.



ARB Winchbumper

This bumper with rounded corners and rubber buffers fits perfectly new and modern 4WD vehicles. The integrated fog lights are available as an accessory. The bumper is painted in a grey metallic finish and the mounting kit for the bumper and a WARN winch are included in the kit. When no winch is installed the license plate will cover the opening for the roller fairlead.



This system is available for the following models:

Nissan Patrol Y61, Rover Discovery II, Toyota J12, Toyota J9, Toyota J100/105, Mitsubishi Pajero V60 and Nissan Pathfinder - new models are added constantly.

NEW! TÜV approval for all models excluding the Nissan Patrol.



ARB Bumper Bar

A stable one piece bumper with integrated bull bar. This outstanding quality and excellent fit bar is a referenced Toyota and Nissan part in Australia.

Replaces the original bumper.

Mounting time 6 hours.

For Warn winches CE M6000 – CE XD9000.

Available in black, newer models in a grey finish.

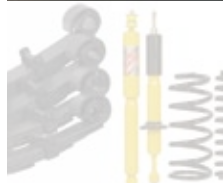



MULTIMOUNT-SYSTEM

Multimount Carrying Set "Big"

Part-Nr.: 1-26375 for winches CE-M6000 bis XDC

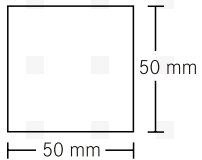

tubediameter:
50 mm



Multimount-System

The mounting system for a winch and other accessories in the future. It gives a lot of possibilities ...

- for vehicles with not enough space to mount a fixed winch.
 - you need the winch only for emergency use.
 - for vehicles which are sensitive on overheating the engine.
 - you can use the winch or the shackle front and rear.
 - when your cross axle load is limited this is the only chance to have a winch.
 - you can use the winch on different vehicles or on your trailer etc.
 - you can use this system on a truck, motorhome, forklift etc.
 - gives you multi-use in the forest or when hunting.
 - for rescue vehicles this should be a standard item to guarantee a quick and safe effort.
- etc. ...



WARN Booster Cable

Part-Nr.: 1-26769
5 m + 1 m with battery connectors



Universal Bow shackle adapter

Part-Nr.: 1-29312
for 50 mm System



Cable with plug

Part-Nr.: 1-32963 175 Amp/ 6 m
for 50 mm System
Part-Nr.: 1-33541 50 Amp/ 6 m
for 25 mm System
other length see pricelist



Winch connected to front receiver



Adapter for standard towing hook
Part-Nr.: 16-217

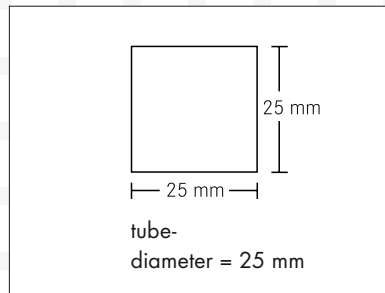

Multimount Carrying Set "Small"

Multimount carrying set, Part-Nr.: 1-2637410 for winches RT/XT 25, RT/XT 30 and RT 40

Additional to our well known multimount set "Big" we designed the smaller version (up to 1.800 kg pulling capacity). Specially for smaller 4x4, SUV's and light commercial vehicles and Motor homes to help them out of difficult situations.

This light winch system is also a helpful tool for work.



Adapter for tow ball

Part-Nr.: 16-215 (large)
Part-Nr.: 16-216 (small)



Adapter with winch hooked on

Important:

- Never use a winch that exceeds the maximum towing capacity of your TOW hitch.
- Always pull in a direct line from the vehicle not at an angle.
- You must ALWAYS use the securing bolt when mounting the multimount.
- Always cover the front receiver when travelling on normal roads.
- The winch should be removed when on the public highway.

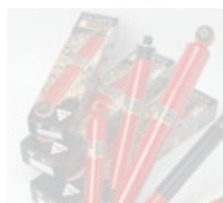

OLD MAN EMU 4x4 Shocks & Suspension

An emu cannot fly due to its massive size, but have you ever seen one of these amazing creatures run? Their powerful legs absorb most of the impact, allowing them to move over all types of terrain with the greatest of ease while their bodies remain virtually motionless.

This is what Old Man Emu strives to achieve with its range of fully integrated 4x4 shocks and suspension systems.

Vehicle suspension, especially when referring to 4WDs, is complex to say the least. Determining the right solution for each vehicle requires special attention to many factors, with weight being the most critical. A single suspension system designed to suit a multitude of users simply isn't practical, as each user's preferences will dictate how the vehicle is outfitted and used. Despite these differences, most aftermarket suspension systems are only available in a single configuration, with lift height often being your only option.



OME – Suspension components

OLD MAN EMU is different!

Instead of offering a compilation of parts that have been chosen primarily to increase the vehicle's ride height, OME offers a range of tuned and matched integrated systems, each offering varying degrees of comfort, load carrying capability & control characteristics. The components are designed by ARB and manufactured in Australia, with an unrelenting, no compromise approach.

Shock absorbers and springs for each new vehicle start off as prototypes, and are tested and modified in a variety of terrains and varying loads. These trials and modifications can take weeks of testing in order to ensure the best possible combination for each application. We test and modify, test and modify and continue to do so far as long as it takes to ensure each shock and spring combination is totally at one with the vehicle, its varying weights and the varying terrain it's to encounter.



Unique triple lip check valve seal offers excellent gas & oil retention.

Eccentric Intake Spring: To overcome unwanted noise, vibration and harshness.

A multi-stage compression valve incorporates a wider range of valve performance resulting in improved vehicle control and ride suppleness.

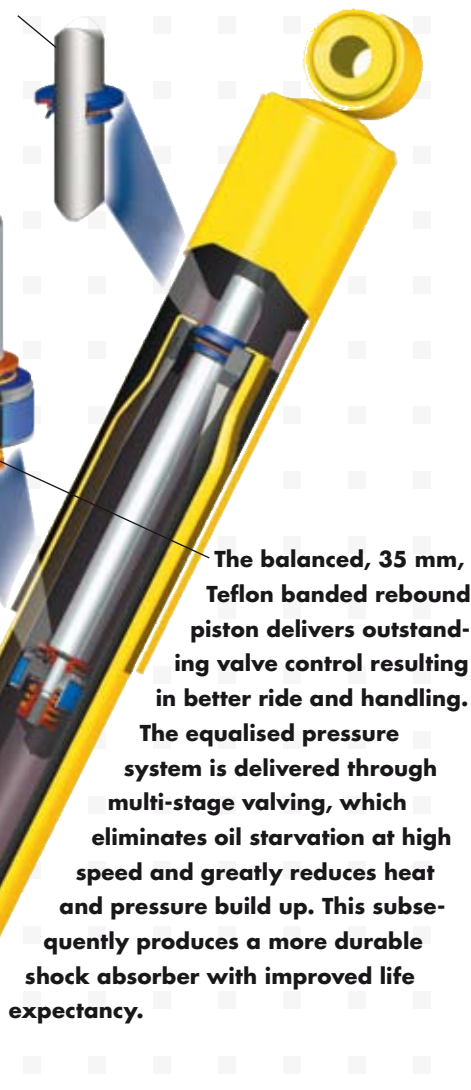

The balanced, 35 mm, Teflon banded rebound piston delivers outstanding valve control resulting in better ride and handling. The equalised pressure system is delivered through multi-stage valving, which eliminates oil starvation at high speed and greatly reduces heat and pressure build up. This subsequently produces a more durable shock absorber with improved life expectancy.

NITROCHARGER

Whilst OME Nitrochargers will improve overall ride performance when fitted with standard springs, more substantial benefits can be achieved when fitted in conjunction with OME springs. Improved ride, load carrying characteristics, and wheel travel are all benefits of such a combination. Built in Australia and used by 4 wheelers throughout the world, OME Nitrochargers set the standard in ride comfort over any terrain and simply out perform the competition.

- Tough urethane bushes for extended life
- Steel stone guard provides maximum protection for the piston rod – where the design allows
- Super strong 18 mm hard chromed piston rod
- Low pressure Nitrogen gas for optimum performance
- Tough twin tube design with super strong 1.6 mm thick reserve tube protects vital internal components
- Supplementary top & bottom welds give added strength and safety

LTR Shock Absorber

Old Man Emu LTR shocks were originally developed for long distance off road events like the gruelling Round Australia Trial – 18,500 off road kilometres in 9 days. LTR's precise handling on high speed dirt roads, their total control over never ending corrugations, and brilliant performance over rutted tracks proved their consistent performance was unsurpassed in all conditions.

The overwhelming success of LTR shocks at competition level led to them being made available for a very select number of vehicles. Their stunning performance and increasing popularity, have however, resulted in more and more applications being progressively introduced. Whether you're carrying heavy loads over rough roads, travelling at high speeds over corrugations or, simply, just want the best shock absorbers available, OME's LTRs are the right choice for your 4 wheel drive.

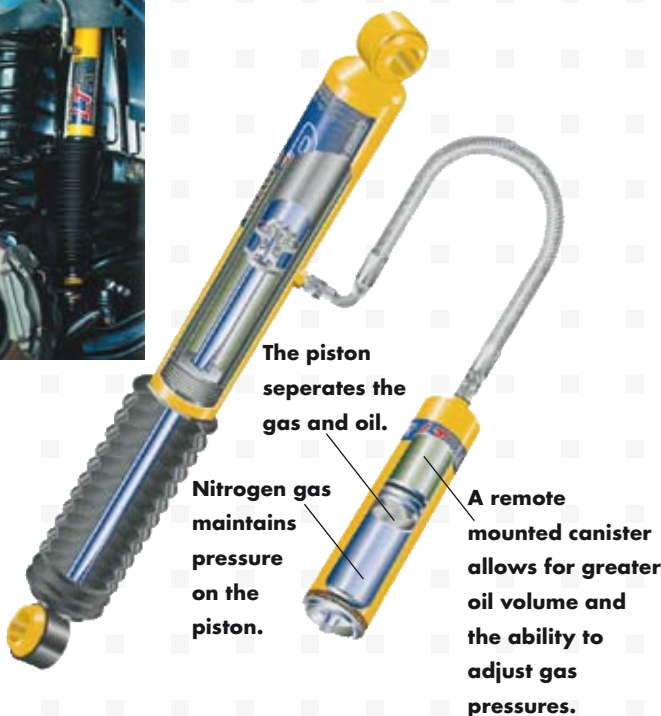

The piston separates the gas and oil.

Nitrogen gas maintains pressure on the piston.

A remote mounted canister allows for greater oil volume and the ability to adjust gas pressures.

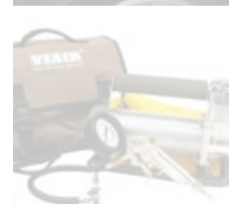
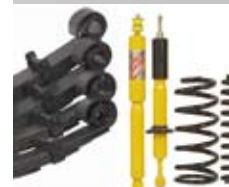

Coil springs

OME coil springs are formed on precision mandrels and manufactured to the highest standards.

A scragging process is performed before and after the coils are shot peened to reduce stress and prevent sagging. Constant and variable rate coils are available to suit a wide variety of applications – even those you thought were impossible.

Coil spring end configurations are designed to exact specifications guaranteeing perfect fitment to your vehicle, while a durable powder coat finish provides a quality appearance for years.



variable or constant spring rates for closer fit to your vehicle

formed with CNC tools for a constant quality finish

shot peened to reduce spring stress and longevity

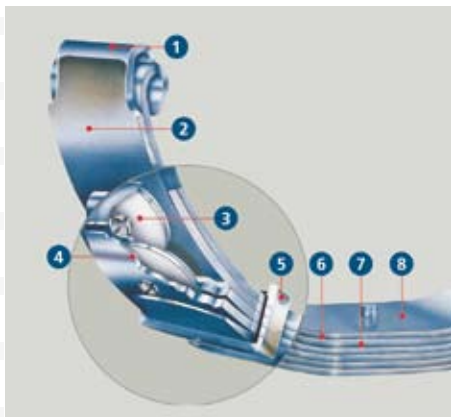

Advantage of OME leaf springs:

1: "Military Wrap", Designed to provide added safety.

2: Draw Tapered & Diamond Cut Leaves, to reduce interleaf friction and to ensure that load distribution occurs at the leaf tips - this significantly contributes to spring life.

3: Anti Friction Pads. Regreasable nylon interleaf liners reduce friction at the leaf tips where the load is the greatest.

4: Graphite Coating. To further reduce the friction between the spring leaves & friction pads.

5: Bolt Clamps & Liners. The leaf clamps are bolted to allow installation of anti squeak nylon liners.

6: Shot Peening. The tension side of all leaves is shot peened to reduce spring stress. This process can double the life of a spring.

7: Flat Axle Seat Area. Allows a positive, safe axle mount reducing spring stress & increasing spring life.

8: Fully Scragged & Load Tested. Scragging ensures the spring takes a permanent "set" which reduces the risk of sagging. Load testing ensures the spring meets the required specification. licensed fitter for further information.





Steering Stabilisers

- 9 Stage Spring Valving – for optimum performance
- 15 mm Piston Rod - stronger than the original
- Steel Stone Guard - protects the piston rod against stone damage
- 35 mm Piston & Bore - increased oil volume
- Twin Tube Design - protects the internal components against stone damage
- Multi lip Seal - prevents oil loss
- Original Mounts - for ease of installation original stabiliser mounts are used where appropriate



Torsion bars

Old Man Emu torsion bars dramatically improve your vehicle's ride and handling, both on road and off. They're designed and set to ensure you get the performance expected from OME suspension, while maintaining maximum wheel travel crucial to off road traction.

Features:

- Manufactured from premium grade spring steel with a resilient powder coat to protect against corrosion.
- Precision drawn, dropped forged ends for optimal strength and integrity.
- Pressure rolled splines for precise fitment and increased spline durability.
- Hardened and tempered to exact specifications for improved performance.
- Preset and hardened to prevent sagging and increase life cycle.



Bush & caster kits

After we saw the high quality of OME bush kits we decided to supply this quality component to fit with original parts. They have the same high quality polyurethane construction giving longevity.



OLD MAN EMU Greasable shackles

OME greasable shackles take the hassle out of the necessary and time consuming maintenance and give increased spring bush life.

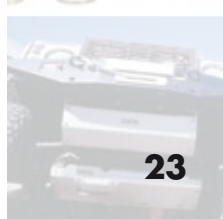



Heavy Track Shock Absorber

Koni has a very long tradition of building shock absorbers for the 4x4 market and the military market. Historically it has been hard to find this shock absorber in the truck and car application lists.

That's why the different shock absorbers for 4x4's are now all listed under "Heavy Track" and why most 4x4 applications are available. You can also choose from the special shocks made for the Australian market to which you can fit longer springs. We have 3 different ranges of "Heavy Track shocks".

Single tube shock with high pressure gas to use where you have tight fitting areas or the angle of the shock fitting makes it necessary. These shocks have part nrs. such as 23-26 or 23-30....

Double tube shocks with no pressure filling, used on vehicles for extreme conditions and where durability counts, and the shock should be easy to repair. These shocks start with part nr. 23-80, 82, 84, 86, 87, 88 or 90.....

Double tube shocks with low pressure gas filling are also used for heavy work, but the set up is more comfortable, the same as the no pressure ones.

Their part nrs. are 23-8040, 8041, 8240, 8640, 8641, 8741.....

The big benefit on double tube shocks versus the single tube is that in hard off road conditions the outer tube protects the shock function. On the single tube a dent in the tube is the end of the shock – because the piston cannot get the full stroke anymore.



Heavy Track RAID The Gigant!

This shock product line from Koni, which Taubenreuther was involved with from the start in the development and market launch, merits a good explanation because it is a different product compared to the rest of the 4x4 shock concepts. Starting with the look – you can see that there is more inside than normal. The engineers at Koni conceived a shock for heavy use on big 4x4 motor homes which need durability and no fading (loss of damping under harsh conditions). The solution was to use as much oil as possible which needed a bigger housing from the Koni truck segment together with a 70 mm diameter. This allows twice as much oil as the normal Heavy Track shock and the sidewalls are 2,5 mm, the piston is 42 mm and 18 mm rods are used in the Raid line. Teflon on the piston and the rod reduce friction and the sealing is made in Viton. The newly developed hydraulic end supports saves the shock from broken shock fittings and axle support belts which are always a handicap for axle travelling. This hydraulic end support was developed for trucks with air suspension transporting heavy containers. Depending on your vehicle it is possible that the shock mounts are not in the middle as normal as we are using the original vehicle mounts for these huge shocks. This is why the Raid shock line is currently only available for the Land Rovers with classic coil suspension, Mercedes G Wagon, Nissan Patrol from 89 on, Toyota Landcruiser from 90 on, plus the Ford Ranger, Nissan D22 and Hilux from 05 on pick up trucks. Some models have only 55 mm diameter due to space reasons. The part nrs. are 23-88..... the 70 mm versions have part.nrs. 23-90....



FSD – frequency selective damping

This new shock absorber line combines two opposite shock absorber concepts, Limousine-like comfort and street contact like a sports car. This system was originally developed for coaches and afterwards adapted for cars and now it is available for the first SUV, the KIA Sorento. The VW Touareg, Porsche Cayenne and the Audi Q7 will follow later this year.

The principle is very simple: The FSD shock has a second valve in the piston which is connected at high speeds (frequencies) with a limited stroke (working range on streets) and stays completely open to give a soft and comfortable ride. The damping power is very low because the second valve reacts slowly and has no time to close during use.

When the piston stroke is longer and the piston speed slower, the valve analyses the change of the frequency and closes down.

This reaction eliminates the stagger of the car because the rebound damping is much stronger. This varying of the two different valve adjustments takes place in fractions of a second. The driver has nothing to think about and doesn't adjust anything themselves. Similar systems are used by the car industry on several vehicles but in the most cases they use electronic or pneumatic systems to do it. For the aftermarket it is too expensive and time consuming to install such a kit. The Koni FSD is a straight mechanical solution and this shock is only a little bit different from a normal replacement shock. The price is a little bit higher but the installation time is the same. These shocks have to be placed on both axles and the vehicle is not lowered or raised to get the perfect result.

4TSHOCKS SHOCK ABSORBERS



4Tshocks. Innovative Technology. Exclusively from Taubenreuther!

Innovative technology for the ambitious Off-roader.

After you've read the last eight pages about our suspension program and have some knowledge about different shock absorbers and applications of a serial production, we want to offer you a new Taubenreuther exclusive product, the 4Tshock. This high end shock is hand-made under our supervision in a small factory. That means that every shock housing is made individually without any machining and finished with valves and pistons to our exacting specifications. Only the highest quality parts are purchased from around the world. It is a 20-time mono tube high pressure shock with external canister adjustable from the outside. Having read the last pages, you're probably wondering why we decided to make our high end shock a mono tube shock, when it has so many negative aspects in off road conditions. But on the 4Tshocks this isn't the case, we want to get the best out of single and double tube shocks combined in our product. The gas and the interrupting piston have been moved into the external reservoir, which allows more space in the main shock housing and gives the same stroke length as in a similar double

tube shock. The fitting area has enough room and the reservoir is welded to the damper housing saving time and material compared to other makes. Special attention was given to the sealing – because of the high internal pressure (20 bar) and the fast strokes which absorb a lot of heat the sealing is very critical. The sealing package has to be of the highest quality and the rod alignment must be perfect. We perfected the alignment with a 22 mm and a 40mm double piston diameter in a 52 mm wide housing. There are some applications which cannot use the 52 mm housing, so instead we use a 40 mm in combination with a 40 mm double piston and 14 mm rods. Together with the 3 mm thick high strength steel tube this combination is a very strong and stiff part. This exacting alignment needs different bushing materials for each vehicle, some have soft rubber, silent, or sometimes uni-ball systems installed. This new product group starts with vehicles made for extreme use in unknown terrains like the Toyota Landcruiser, Landrover Defender/Discovery and the Mercedes G-Wagon. The expansion of the product line is under development including the new SUV's.



The advantages:

- 52 mm high strength (3mm) housing
- High oil volume inside the external reservoir for better cooling
- Huge 46 mm double piston with 22 mm rod
- Ultra fast and sensitive reaction with high or slow piston speeds up to 10 times valve adjustment
- 20 times adjustable externally
- Special bushings for each vehicle
- 360° welding around the fixing connections
- Housing chromed for best possible rust resistance
- Can be dismantled for repair and service
- Simple to mount and possible to combine with OME springs
- Custom made set ups and changes possible

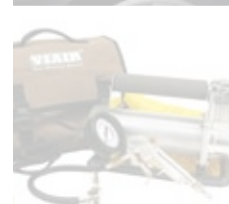

HUBS



WARN "Hubs"

Warn Hubs began the off road performance revolution in the late 1940s. At this time Arthur Warn owned a Jeep dealership in Seattle. He noticed that the early Jeeps had an Achilles' heel: even in 2WD the front hubs engaged the axle shafts, gears, U-joints and drive shaft exerting unnecessary wear and tear. Warn's solution was a specially designed hub that had no center drive flange allowing Jeep front axles to free wheel thus minimizing stress to the costly front end components.

Since this time many more hubs are available and WARN has models available for closely all 4WD vehicles and supplies car manufacturers around the world.

AVM "Hubs"

Additional to our WARN Hubs we now offer the complete range of AVM Hubs. The function is similar to the WARN Hubs but the product line is much wider and we can offer hubs for most 4x4 vehicles on the market.

HOFMANN Wheel extension

The proven Hofmann wheel extensions are fitting perfectly in our sales program. We think that they are the optimal addition when you lift a vehicle with standard wheels. The subjective impression of more unstable handling is compensated by the 60 mm widening of the axle width. Hofmann wheel extensions are for most vehicles supplied with a TÜV homologation with the standard wheels.





Vario

The Vario is the flagship of the scheel-mann seat range. The many variations available for this model are what makes this such a good seat. The seat can be sporty – or just nicely comfortable and on longer journeys you can adjust various parts of the seat for a higher level of comfort. On the Vario E everything is adjustable by a simple push of a button!

Vario XXL

The difference here is the extra high seat back especially for taller people making a perfect driving position and comfortable at the shoulders.

Configurations

Material samples showing leather like covers. Other colours and materials available on request. A folding backrest and the movable headrest are standard features on all models.

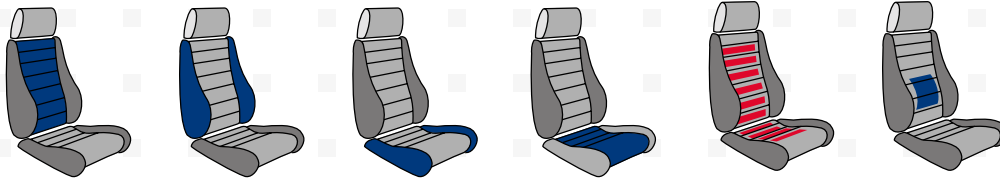

	Backrest	Backrest side	Seat sides	Seat length adjustment	Seat heating	Lumbar support
Vario	standard	adjustable	flat	●	○	● manual
Vario E	standard	adjustable	flat	●	○	● electric
VarioE/HZG	standard	adjustable	flat	●	●	● manual
Vario XXL	high	adjustable	flat	●	○	● manual
Vario XXL/E	high	adjustable	flat	●	○	● electric

○ optional
● serial

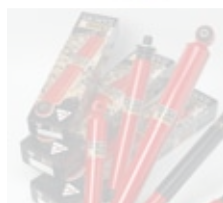



FULDA Tramp 4x4 Trac



FULDA Tramp 4x4 Tour



FULDA Tramp 4x4 Mix



DIRT GRIP AMT



**GOODYEAR
Wrangler MT/R**



**GOODYEAR
Wrangler AT/R**



**GOODYEAR
Wrangler Silent Armor**



GENERAL Grabber AT2

Special Wheels with a modified suspension system

When our customers modify their car's suspension system, frequently they are inquiring about new, bigger tires with AT or MT-profiles. Therefore we have increased the availability of this special program during the last few years. It is very simple to mount a 1-3" bigger wheel after having modified the suspension system. However, the simple fact that the wheels are fitting and do not scratch the wheel housing, does not mean that you can get an homologation. Depending on the model of the car and the size of the tire, you do not only need driving tests but the vehicle needs to pass complicated and expensive emission, brake and wheel load tests. In order to minimize cost and offer a clear range of products, we started to collaborate with the biggest manufacturer of aluminium wheels for 4x4 vehicles in Europe,

CW which belongs to the Borbet group. We have updated numerous homologations, have tried many wheel and tyre combinations, and have passed new homologations and are now able to offer special wheels for each suspension system. A list of all possible combinations would be too extensive for this catalogue but we have a pricelist "special wheels" that contains all this information. Please understand that not all combinations are possible for each suspension system. Due to logistical reasons, the choice of wheels and tires is restricted to models shown on the next page.





Rover Discovery II with 8 x 16 CV und GoodYear Wrangler MT/R 245/75 R16



CW 8 x 15 / 8 x 16



CV 6,5 x 16, flat cap



CV 8 x 16 / 8 x 18, high cap



CD 7 x 15 / 7 x 16



CWA 8 x 17



CW 7 x 16



CWE 8 x 17 / 7 x 16



CWB 8 x 18 / 9 x 20



DOTZ Steel wheel rim



Indy 7,5 x 16



Alpin 7,5 x 16



DOTZ Hammadada 7 x 15 / 8 x 16 / 8 x 17 / 8,5 x 18



The VIAIR Compressor Program

When searching for new suppliers we came across the American market leader, VIAIR. On the next three pages are the details of these products. From the smallest portable compressor, the 90 series, for light work to the heavy duty professional 550 series.

Combined with the pressure reservoir you can also work with air tools and there is something for everyone amongst the models available. Look for the complete range of accessories on offer with the different manometers working in psi and bar to the spiral air tubes and the special tyre valves.



The 90P is a small but powerful portable compressor. Strong enough to pump up a 31" tire and supplied with a pressure gauge.



The 400 P is one of the most popular portable compressors from VIAIR. Useable up to the tire size of 33x12,5 R15. Simple to use and very strong. The supplied battery connectors make it easy to attach to the battery poles of any vehicle. Supplied with a spiral air hose and pressure gauge with wheel attachment.



The 440P is the newest model from VIAIR. It's possible to pump tires up to 35" with ease. Connect the battery and plug the pressure line to your tire valve and that's it, it works!



The VIAIR 450P-Automatic is the first portable compressor suitable for extended running. It can be operated at a pressure of up to 7 bar for hours on end without interruption. It has an automatic sitch-off function if no air is required. A simple push on the filling gun is all that is required to switch the compressor on again.



VIAIR INSTALLATION COMPRESSOR



VIAIR 325C

the starter model for your own on board air pressure system.
Part-Nr.: 34-32530 12 V Part-Nr.: 34-32538 24 V



VIAIR 460C

new model, new design for constant use: price performance ratio in table: Model. Part-Nr.: 34-46043

Please ask for the new Series!

Part-Nr.	Model	Cyclic duration	Compressor flow rate		max. AMPS	Weight	Dimensions L x B x H in mm	Recommended tire size
			0 bar	2,5 bar				
34-00093	90P	15 Min.	50 l	30 l	21 A / 12 V	2,6 kg	172 x 157 x 93	31 x 10,5 R15
34-40043	400P	45 Min.	72 l	55 l	29 A / 12 V	3,8 kg	253 x 100 x 170	35 x 12,5 R15
34-44043	440P	45 Min.	85 l	59 l	34 A / 12 V	6,2 kg	330 x 148 x 170	35 x 12,5 R15
34-45043	450P	several hours	47 l	37 l	19 A / 12 V	5,8 kg	318 x 152 x 184	35 x 12,5 R15
34-32530	325C	30 Min.	50 l	34 l	19 A / 12 V	3,2 kg	203 x 102 x 179	33 x 12,5 R15
34-32538	325C	30 Min.	40 l	30 l	10 A / 24 V	3,2 kg	203 x 102 x 179	33 x 12,5 R15
34-46043	460C	several hours	47 l	36 l	18 A / 12 V	4,8 kg	292 x 109 x 165	35 x 12,5 R15

All data in the above table is approximate depending on your electric energy source, the temperature, the sea level and the length and diameter of the pressure tube.
All VIAIR compressors have anodized aluminium cylinders. Stainless steel valves and PTFE piston rings. That is why these compressors can work without oil which is very important when refilling tyres. They are dust and showerproof and driven by a permanent magnum motor with a high torque and integrated thermal switch. The compressors comprise a bag, 2,5 m cable, crocodile clips, 7,5 m spiral tubes and pressure manometer.

The 90P and 440P models also include an adaptor for refilling balls, air mattresses etc. The stand alone models come with a steel flex tube, quick connectors and rubber stoppers. Please note that when the compressors are used they must be allowed to cool at a ratio of 4 cooling to 1 running time.

Attention: when choosing a compressor, the cooling time can be 3-4 times of the running time!!

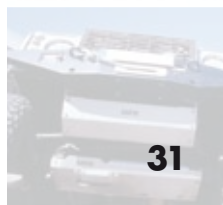

Two new air supply systems from VIAIR: Complete kit

A clever idea from VIAIR: complete kits that contain all the components needed to build an air supply system – including all accessory and mounting parts. And the best is: the kits are significantly more cost-effective than the sum of the individual prices. Taubenreuther has two sizes of compressor kit in stock – “Medium” and “Constant” – according to application.



VIAIR compressor kit “Medium”

VIAIR’s “Medium” compressor kit is designed for continuous operation for up to 30 minutes and achieves a maximum working pressure of 10 bar. It is suitable for inflating tyres, and also for the operation of small compressed air tools or horns.

The “Medium” compressor kit contains:

- one 9.5 litre air tank
- one VIAIR air compressor 325C
- one 1/4” quick-release coupling (F)
- one 1/4” NPT connector (F)
- one operating panel with on/off switch and pressure gauge
- one pressure switch with relay (7.2 -10 bar)
- one reducer (1/8” NPT F on 1/4” NPT M)
- one 1/4” NPT 12.5 bar relief valve
- one 1/4” bleed valve
- three 1/4” NPT fittings
- one 10 cm cable protector
- one 6 m cable set with safety device

Order no. 34-10003

VIAIR compressor kit “Constant”

The VIAIR “Constant” compressor kit is designed for continuous operation and achieves a maximum working pressure of 10 bar. It is suitable for inflating tyres, and also for the operation of small compressed air tools or horns.

The “Constant” compressor kit contains:

- one 9.5 litre air tank
- one VIAIR air compressor 450C
- one 10 m air hose
- one 1/4” quick-release coupling (F)
- one 1/4” NPT connector (F)
- one operating panel with on/off switch and pressure gauge
- one pressure switch with relay (7.2 -10 bar)
- one reducer (1/8” NPT F on 1/4” NPT M)
- one 1/4” NPT 12.5 bar relief valve
- one 1/4” bleed valve
- three 1/4” NPT fittings
- one 10 cm cable protector
- one 6 m cable set with safety device

Order no. 34-10007



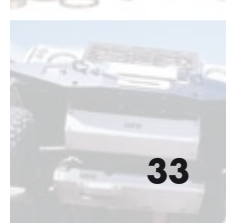
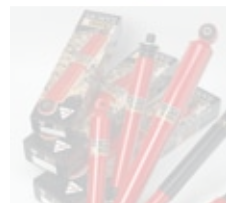

Air tank



Compressor
with stainless steel lead hose



Mounting kit for air system from 5,8-7,2 bar (Part-Nr.:34-20053) or 7,5-10 bar (Part-Nr.:34-20052)

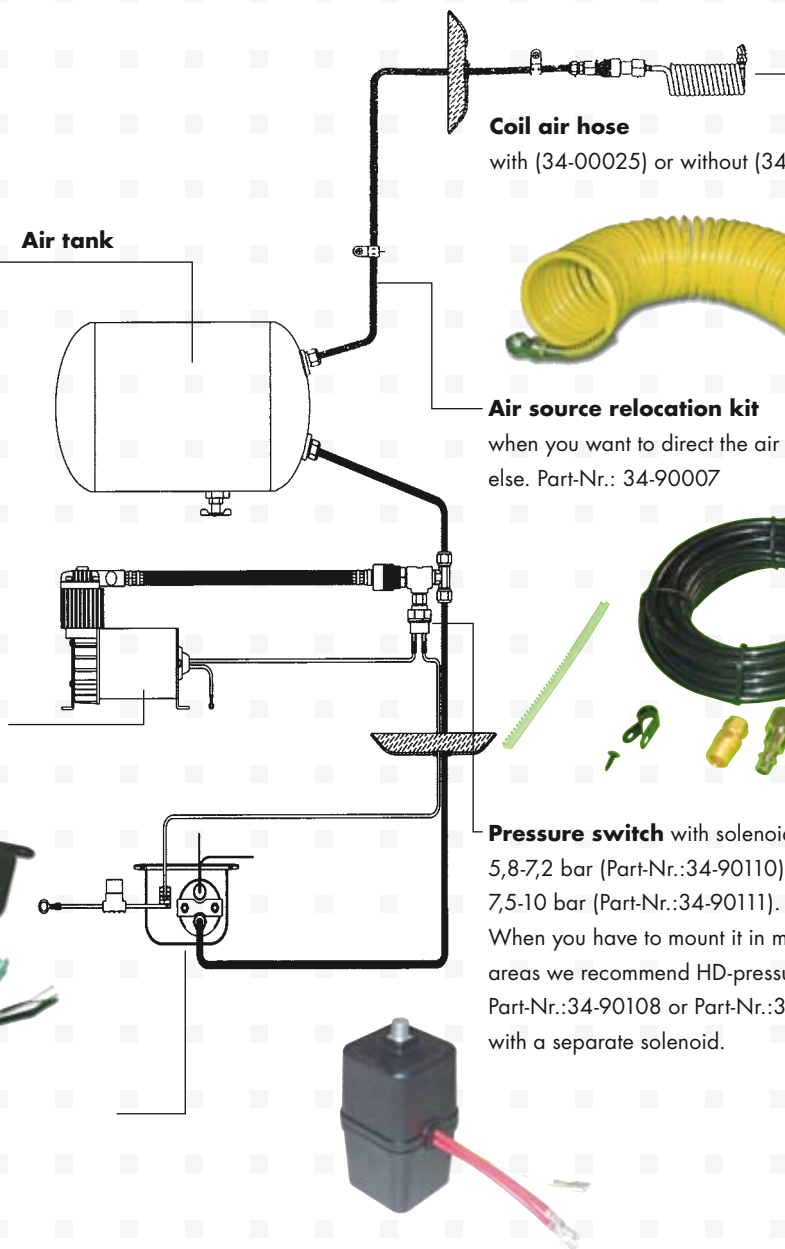

Coil air hose

with (34-00025) or without (34-00035) gauge.



Air source relocation kit

when you want to direct the air somewhere else. Part-Nr.: 34-90007



Pressure switch with solenoid from 5,8-7,2 bar (Part-Nr.:34-90110) or 7,5-10 bar (Part-Nr.:34-90111).

When you have to mount it in muddy areas we recommend HD-pressure switch Part-Nr.:34-90108 or Part-Nr.:34-90109 with a separate solenoid.

Air tank

34-91010 = VIAIR Air tank 3,8 l mit 2 x 1/4" connector
measurements: l = 261 mm x d= 153 mm

34-91025 = VIAIR Air tank 9,5 l mit 6 x 1/4" connector
measurements: l = 610 mm x d= 153 mm

34-91050 = VIAIR Air tank 19 l mit 4 x 1/4" connector
measurements: l = 508 mm x d= 256 mm





COMPRESSORS

WARN Air-Power VTC

With an abundance of power from this high-horsepower fan cooled motor, Vtwin configuration, and large one gallon integrated intercooler and reservoir, the Air-Power VTC is the highest performance compressor in the WARN Air Power lineup. The VTC is ideal for powering air tools, rapidly airing up everything from tires to rafts, powering air suspension systems, and just about anything else that needs air. It comes with a removable carrying cage so you can easily transport it or hard mount it to a vehicle or trailer. A pressure cut-off switch turns the compressor off when it reaches 100 PSI and back on at low pressure, and a quick-connect hose outlet makes air hose connection fast and convenient. With all this power and all of these features, the VTC is a force to be reckoned with.

Part-Nr.: 1-75789



WARN Air-Power SPI

Big Power, Compact Size

The versatile WARN Air-Power SPI has the features you want and the performance you need, and is compact enough to be mounted almost anywhere. Its powerful fan cooled motor and robust single-piston design make it well suited for powering an air suspension system for on-road or off-road vehicles. Its integrated 1/3 gallon reservoir and intercooler means cooler outlet air temperatures and longer hose life. The SPI is also powerful enough to run non-continuous duty air tools, such as air nailers for the jobsite. A pressure switch automatically shuts the unit down when it reaches its maximum pressure rating and turns it back on when pressure drops below an efficient level. No matter how you use it, the WARN SPI is going to be up to the task.

Part-Nr.: 1-76800



Motor:	12 Volt
Max Pressure:	100 psi / 7,5 Bar
Airflow Rating:	566 l/min at 0 bar, 226 l/min at 6,5 bar
Intercooler/Tank Vol.:	3780 cm ³

Motor:	12 Volt
Max Pressure:	100 psi / 7,5 Bar
Airflow Rating:	283 l/min at 0 bar, 113 l/min at 6,5 bar
Intercooler/Tank Vol.:	1300 cm ³



The new portable High-Output Compressor from ARB

- in a strong and roomy plastic box
- protected against dust and moisture
- hardened and coated cylinders
- Kevlar piston rings and Teflon® coated
- the compressor automatically shuts off via a pressure switch when the job is stopped for any reason.
- the electrics are protected by an internal fuse
- high quality components giving low noise level and the lifetime pressure valve gives extra security
- the bronze airfilter is washable
- a lighted and isolated switch protect the user from flying sparks when
- connecting the battery clamps all important spare parts are available included in the kit = 6 m high flexible with connectors for tire valves
- and adapters for camping and toys

Part-Nr.: 2-00041



Technical data:

voltage:	12 Volt	
amp draw:	13 - 23 A	
Air flow rating:	Liter per minute	bar/counter pressure
	75 l	0 bar
	61 l	2 bar
Weight:	6,6 kg	
Size: H/L/B	21/44/24 cm	

Rescued by a case: the ARB tyre repair kit

If remote from the dense service network in our part of the world damage to a tyre can quickly become a big problem that makes any onward journey impossible. ARB now offers the solution: a complete tyre repair kit for tubeless tyres in a strong case that contains the following items:

- a tyre pressure gauge
- lubricant
- valve accessories
- reamers
- 30 repair cords (can also be supplied as spare parts)
- 2 Allen keys

Part-Nr.: 35-ARB1000010



ARB tyre pressure reducing valve

A really clever new accessory from ARB is the tyre pressure-reducing valve with a rapid bleed function that makes it very easy to reduce the air pressure for off-road use. And this is the way it works: Firstly the brass attachment is placed onto the valve and then the valve insert is rotated outward – in this way it cannot be lost. The desired tyre pressure is now set by means of a sliding valve mechanism. This can be a very precise process, since the tyre pressure can be read from the pressure gauge. The valve insert is then screwed in again, and that's it!

Part-Nr.: 35-ARB500



With the new tyre pressure reducing valves the pressure in the tyres – thanks to the rapid bleed function and pressure gauge – can be lowered easily and precisely.

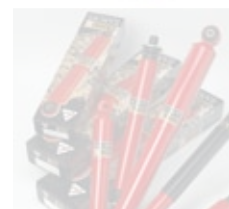

100 % differential airlocker – How the airlocker works

The ARB differential airlocker is available for many types of vehicles. The ARB airlocker has the advantage of being controlled by the driver, by means of a dashboard mounted switch. There is no chance of unexpected engagement, this means the locker is either disengaged or 100 % locked, so no adverse effect to your tyres when travelling on normal roads.

When turning it on by pushing the button, the compressed air activates a piston inside which engages a locking gear, instantly locking the differential. By simply switching it off, the diff lock is disengaged and the diff lock works as an open differential, maintaining safe and predictable handling.

Using a compressor (works best with original ARB compressor) you provide the pressure needed for the bonnet. The automatic switch on the ARB compressor always provides the right pressure. Using the dashboard mounted switch you can choose when to use the diff lock.

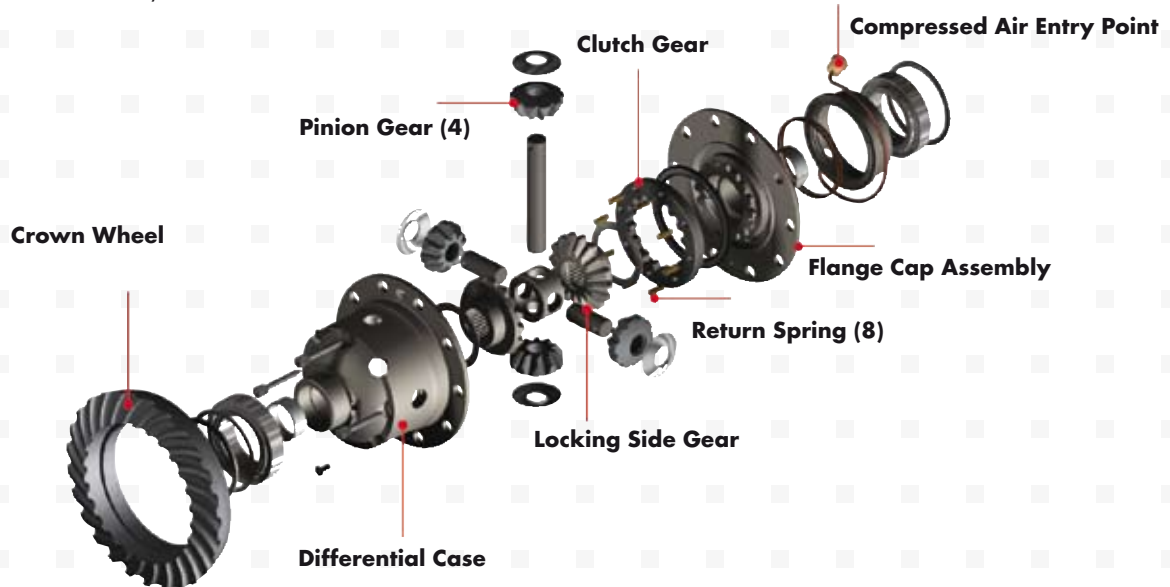

ARB Air Locker

The Airlocker is the most popular part in the product range. ARB has built over 200.000 units, with this experience the quality level was built up over the years. More than 100 versions are available today – no other supplier has such a wide range.



ARB High Output Compressor

The third generation of the ARB compressor not only gets the high output it boasts - the increase in power is over 100%. This unit can pump up to 75 l/min with less power input. The new mounting system allows you to turn the compressor up to 180° and makes it an easy part to install. The mounting kit is the same as it is in the ARB Compact compressor and in the prior model.

Part-Nr.: 2-00011 (12 V)

Part-Nr.: 2-00022 (24 V)



ARB Compact Compressor

This compact vehicle mounted Air Locker Air Activation System has been specifically designed to activate ARB Air Lockers, meeting the demanding needs of users. A smaller unit, it comes with a mounting bracket that allows versatile positioning and is sealed for moisture and dust resistance with quality components used for quiet operation and extra long life.

size: 162 x 88 x 122 mm

voltage: 12 V

max. air flow: 25 l/min.

Part-Nr.: 2-00010, 12 Volt



Air locker switches in the vehicle.

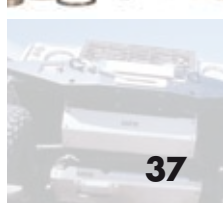
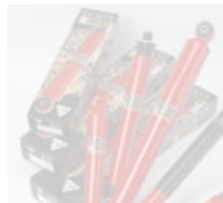



DIFFERENTIAL COVER

ARB differential cover for Dana axles and Land Rover

The ARB differential cover is manufactured from an extremely robust cast iron that is harder than steel. The cover protects the differential and also the pinion and crown gears particularly effectively in the event of heavy ground contacts, while at the same time the flat shape provides good ground clearance under the axles. In addition the ARB cover, thanks to its computerised design, increases the torsional stiffness of the overall axle geometry by 1,300 Nm – as a result the pinion and crown gears run without any torsional stresses, thus increasing their service lives. An integrated oil dipstick not only allows checking of the oil level, but also shows whether water has penetrated into the differential. Finally magnets on the oil drain plug and dipstick also capture metallic particles and provide early warning of incipient damage or increased wear.

ARB differential cover compatible with

- Order no. 2-0750001 DANA 60 and Land Rover Salisbury axle
- Order no. 2-0750002 DANA 30
- Order no. 2-0750003 DANA 44
- Order no. 2-0750004 DANA 35 and DANA 35C





BUMPERS / SKID PLATES

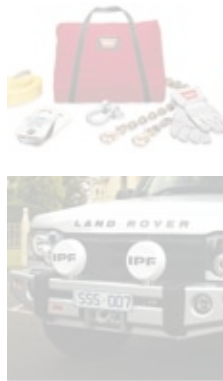

Steering Box Skid Plate

The full enclosure skid plate has been designed to fit within 1/4" of the steering box for maximum ground clearance over those big rocks. It also means full structural rigidity so when the rocks hits come, there's minimal deflection. It also has drain holes to clear debris without sacrificing structural support. Made from 3/16" steel and black powder coated. Steering Box Skid Plate for Wrangler TJ,

Rock Crawler Fuel Tank Skid Plate

Put some thick, 3/16" steel between your gas tank and rough terrain your Jeep will conquer. The WARN Fuel Tank Skid Plate for the Jeep Wrangler not only adds an extra inch of clearance over stock setup, it bolts right onto the body using the existing factory attachment points. Drain holes help to keep the plate free of debris. Durable, black powder coat finish fights off rust.

Differential-Cover

Angled for a tight fit and structural rigidity, the Differential Skid Plate fits both high and standard pinion covers to give full protective coverage. Since it is a closed system, it slides over objects and won't snag or hang up. Made from 5 mm steel. .



Rock Crawler Front Bumper

There's only one reason to introduce another bumper to the world of Jeep® vehicles. Because the Warn bumper incorporates our off-road experience to deliver a tough, durable well thought out product. Let's start with the tapered ends for increased approach angles. The front bumpers have welded eyelets to mount D-shackles and predrilled holes to mount lights. Available for Jeep brand CJs, YJs and TJs, the Warn bumpers are laser cut from 3/16" steel, then CNC formed, robotic-welded for precise fit and powder-coated for durability.



Rock Sliders

How many body shots can your Jeep absorb? A heck of a lot more with Warn's new Rock Sliders. The thick 3/16" reinforced steel plate bolts right to the Jeep body, reinforcing its weakest spot. Black powder coat finish.

Mounting hardware is included. Some drilling required.



Rock Crawler Rear Bumper + Tire Carrier

This tough, durable bumper gives maximum off-road performance. Tapered ends allow for increased approach angles. An integrated 2" receiver allows mounting of your portable winch or shackle bracket to increase your recovery options. Available for Jeep CJs, YJs and TJs, the Warn bumper is laser cut from 3/16" steel, then CNC formed, robotic welded for precise fit and powder-coated for durability.



Fits perfectly and completely protects

Custom made for each vehicle. A system of individual components protecting the vehicle undercarriage from damage. Available for most SUV's, 4x4 and Pickup's. Manufactured of strong and stable 6 mm thick Aluminium.

This high quality product is new to us and we already have a lot of enquiries and orders. Because they are specially made for each vehicle the product line is huge. On some vehicles we have up to 4 different plates which can be mounted separately or in various combinations to achieve full protection. This outstanding system of skid plates for off road vehicles is well designed, high performing with a quality finish. The various skid plates protect the underbody parts of the vehicle such as the gears, transfer box, fuel tank, oil tube, coolers, muffler and more.

ASFIR Skid Plates bolt to the original holes in the vehicle chassis. Service openings in the plates enable servicing the vehicle without dismantling. Skid protection.

This product not only gives the serious "Off-roader" more security in harsh terrain but it also helps to protect working vehicles or outdoor campers from unpleasant surprises. The modern SUV's have a lot of power but no gear reduction and in most cases not a lot of ground clearance. Often it is difficult to mount off road tires, so in harsh conditions they use more speed which can rapidly cause expensive damage. That's why you should protect your vehicle with our skid plate system.

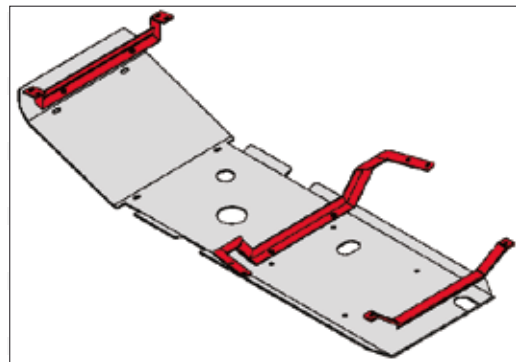

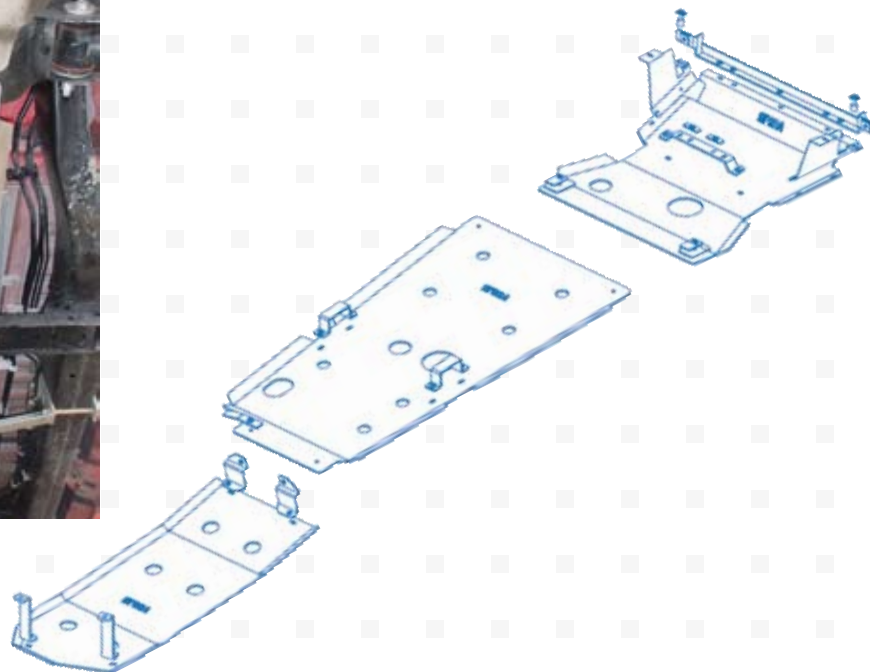



DSBHD Clutch with Aluminium Flywheel for Nissan Patrol Y61



Suzuki clutch with clutch disc HD,DCB and DSB



DSBHD clutch with steel Flywheel for Toyota Landcruiser

ACS-Clutch



Once more our research uncovers a very interesting product. The Australian market leader - Australian Clutch Service (ACS) have developed a range of clutches. On many of the new vehicles the clutches wear out under normal conditions very quickly. When frequently using a trailer, adding bigger wheels or motor tuning the stress on the standard clutch is too high. One of the solutions is a stronger clutch system.

The normal HD and XHD of the Xtreme Outback series, which is developed for 4x4 vehicles will increase the strength by up to 50% of the standard clutch .

Both of these clutches have an organic surface and this, together with special clutch covers, gives a much improved performance clutch under extreme conditions as well as an improved clutch for day by day use.

The next in the range is the DCBHD and DCBXHD with increased friction values using a Sinter metal surface and stronger clutch covers. Although they can be used for normal daily use we recommend them for heavy duty trailers and improved power for Rally vehicles

At the top of the range, primarily for racing, are the DSBHD and DSBXHD. These clutch discs have star shaped wings with Sinter metal giving a higher friction value like the DCBHD. In combination with the correct clutch cover it is ideal for motor sports

For many vehicles we can supply light aluminium flywheels or steel flywheels to replace the original 2 masses flywheels.

All clutches are delivered in kit form including clutch disc, clutch covers, clutch release sleeve and a clutch thorn for the simple fit.



**Better heat absorbing through
"Kangaroo Paw"**



**DBA Slotted for standard applications
like pulling trailers and heavy loads**



**DBA Gold – slotted for the best
performance on and off road with
the noted addition of TTM and TSP**



**Serie 4000 Wiper Slot – slotted for the best
performance On and Off Road with
additional advantages of TTM and TSP**



**Serie 4000XS the top model available
with perfect optics and stability thanks
to TTM and TSP**

DBA Disc Brakes



DBA (Disc Brakes Australia) is a six times award winner of the Accessory Manufacturer of the Year award in Australia. To start with the manufacturing of simple replacement discs was their focus - since then a lot of development work has taken place in performance parts for 4x4 vehicles and race discs for motor sports.

We used our first DBA disc 8 years ago in one of our off road race cars. The superior brake performance, even in wet and muddy conditions, convinced us. That's why we are now offering this product to our motor sports clients and special vehicle builders with a selection of these high quality discs. A certification from TUV for the 4000 Wiper Slot is under development.

DBA's Kangaroo Paw delivers significantly improved braking performance under all conditions to make you safer than ever before. This innovative design runs cooler, is stronger and outperforms traditional straight disc brake rotors.

Extreme heat can cause disc rotors to warp, distort and in some cases fail. Traditionally, heat is removed as air flows through the rotor passing between straight 'cooling vanes'. Kangaroo Paw disc rotors will quickly remove the heat, cool the discs and return to optimal operating temperatures ready for the next braking application. The Kangaroo Paw features 144 precisely positioned diamond and tear-drop pillars. The pillars create greater strength, reliability, and more efficient cooling system. Greater surface area means more rapid heat dissipation.

On the 4000 Series you will find 2 more DBA Patents – "Thermo-Graphic Temperature Monitoring" (TTM) and "Thermal Stability Profiling" (TSP).

TTM is a Graphic paint marking which changes colour at specific temperature thresholds – the driver can check their braking performance. TSP = the process provides greater thermal stability than standard street discs. TSP enhances the microstructure of the rotor for performance applications.

All rotors have a better brake performance because of the directional/wiper slot design and cleaner disc surface. All these positive effects will help already with standard disc pads for a much better brake performance and the fading is noticeably reduced. To get better (no a) braking in wet conditions the Gold or XS versions with additional holes should be the choice although these are not suitable for Off Road use as the holes can fill with mud - so they are only for street use.

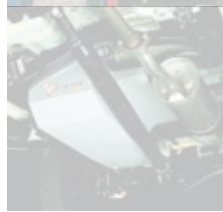



2 ½ muffler systems

Vehicle	Part nr.
Toyota 1HZ 75/78 Series	14-3201208000
Toyota 1HZ 80 Series	14-3201308000
Nissan Patrol Y61 from 1998	14-4201408000

Please Note:

Due to very specific and targeted applications and therefore low sales volumes we have decided not to do a TUV homologation for this product line or it would be price prohibitive to our customers.

Turbo Systems from AXT

AXT is an specialist company in turbo and intercooler systems. Whether you need power for motor sport, more torque in working applications, you are planning a tour with a heavily loaded 4x4 or have a medium to heavy armed vehicle - AXT Turbo systems may have the answer.

In the basic mounting kits are all the necessary parts for fitting the Turbo/air ducts/hoses/stainless oil tubes/exhaust front and other mounting materials.

We recommend fitting these kits in a good, experienced workshop that has prior experience!

Vehicle	Turbo kit Part-Nr.:	oil cooler kit Part-Nr.:	Water/Air Inter-cooler** Part-Nr.:
Mazda/Ford Pickup 2,5 l (without Turbo)	14-2601000000	–	14-2601341000
Toyota 3B Motor to 5/88	14-3051100000	14-3051105000	14-3051341000
Toyota 3B Motor from 5/88	14-3051300000	–	14-3001341000
Toyota 2L Motor Hilux/Taro	14-3401100000	14-3401105000	14-3401141000
Toyota 1HZ Motor 75/78 Series	14-3201200000	14-3201205000	14-3201241000
Toyota 1HZ Motor 80 Series	14-3201300000	14-3201305000	14-3201341000
Toyota 1HZ Motor 100 Series	14-3251000000	14-3251005000	14-3251341000
Toyota 2H Motor 75 Series	14-3301100000	14-3301105000	14-3301145000
Toyota 2H Motor 60 Series	14-3301300000	14-3301305000	14-3301341000
Nissan TD25/TD27 (without Turbo)	14-4001100000	14-4051105000	14-4001141000
Mitsubishi L200 4D56	14-5001100000	–	14-5001141000
Mitsubishi L200 4D55	14-5001200000	–	14-5001241000

* additionally we can supply an extra oil cooler kit for all 4 and 6 Cylinder Diesel engines (oil cooler/mounting frame/ adapter for oil filter / high temperature hoses)

** for extreme areas you can buy water/air Intercooler (water/air intercooler/waterpump thermo cooler/ cable kit / pressure sensors / high temperature hoses)



ARB Rear Bars

Built to the same uncompromising standards as our bull bars, all ARB rear bars incorporate a heavy duty towing system and will in most cases accommodate up to two tyres or a tyre and a jerry can holder.

There are many benefits associated with fitting a rear bar to a vehicle. Many 4WDs have their spare tyre positioned underneath the vehicle making it difficult to access and vulnerable to damage, particularly in harsh off road environments. Others have their spare tyre mounted on the back door, which can place stress on the door hinges, resulting in rattles and compromised dust sealing as increased wear is put on the door assembly. Both of these mounting methods can also prove unsuitable if larger tyre size is sought.

An ARB rear bar addresses all of these issues, relocating the spare tyre onto the bumper assembly via a swing out carrier. Jerry can holders are also available, along with Hi-Lift jacks.

Operation of the swing out carriers couldn't be simpler. Slight pressure applied to a lever opens each carrier with a gas strut holding the carrier in the open position, engagement of the locking pin only being necessary if the vehicle is on an extreme side angle. The carrier can be closed with a simple slam shut, with the spring loaded locking pin automatically disengaging as soon as the weight is released.

TÜV – under development.

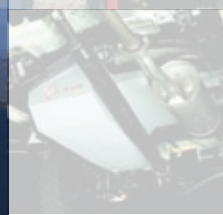



1
Top rail sits well above rack floor to ensure a secure load.

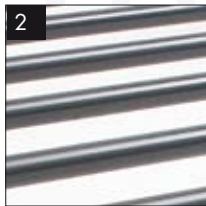

2
Evenly spaced crossbars support the load which is rated to carry up to 150 kg.



3
MIG welding is used on the joints to ensure the optimum strength of each rack



4
Top rail is constructed from tough, 25mm seamless steel tube, bottom rail utilises 35 mm tube.



5
Rails are bent with a mandrel bender ensuring an even wall thickness across all sections



6
Millenium grey powder coat with zinc-rich primer that gives 1000 hours of salt spray resistance.



7
Air deflector plate significantly reduces wind noise.



8
Full length, zinc annealed steel support channel with plastic protection strip to distribute load.



9
Pressed steel feet and legs are height and width adjustable, allowing multi-vehicle installation.



10
Stainless Steel fitting hardware.



11
Unique, super-strong clamping system that's easy to install and remove



Variable height fitting kits allow even greater flexibility for multi-vehicle application.





Roof Rack Systems

A product made by ARB Australia!

With always bigger requirements on solid roof racks – ARB has developed a product which can stand the harsh conditions in Australia. This rack also works well on normal streets and highways. The roof rack is available from 1050 x 1250 mm up to 2200 x 1350 mm with specific mounting hardware for each vehicle. This metal rack has a dark grey powder coat finish. The max load capacity (6 feet mount only) is 150 kg (check the recommended load of your vehicle). New! Racks for the newer pick up double cab models.

On all applications the top rail gives extra strength and holds the load in place. The front air deflector plate together with the optional wind deflector reduce wind noise.

A new addition is the optional awning, fits easily on most roof racks or roof bars and comes in a PVC bag. Supplied complete with mounting hardware and comprehensive instructions. Total length 2480 mm with a roll out width of 2100mm

Part-Nr.: 35-ARB0108

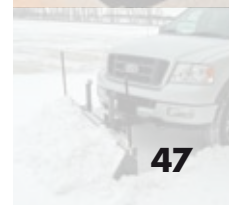
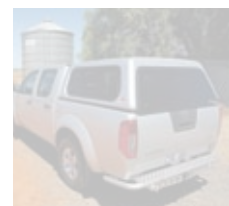
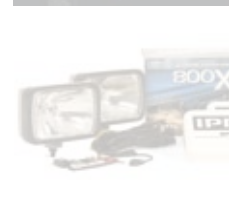
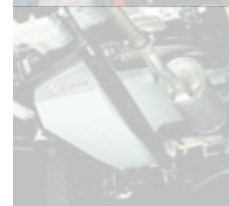
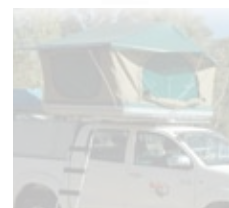
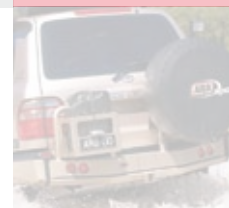

African Outback Roof Racks

African Outback roof racks are made of aluminium. The racks are acid treated, powder coated and finished with a clear lacquer. This protects against corrosion. A rail system allows the attachment of various adapters for canisters, spare wheel, hi-lift, etc.

The racks were tested in South Africa on a load of 300 kg (please check the max. roof load released by the car manufacturer!). Due to its construction, a roof tent can be mounted.

The rail is available in two versions: full size and half size and has to be ordered separately. The rail is screwed on and can be fixed or removed separately from the rack. In most cases you fix the rack in the eaves gutter or on the standard fitting point of the roof. Some car models require that you drill holes through the roof. Fitting instructions and mounting parts are included with the rack.



This is how you can build up this roof rack system. From a simple flat rack (photo no. 1) to a fully equipped rack (photo no. 6). The rail system allows you to slide in and fix various accessories. Photos 7-10 show the different foot kits which are supplied specifically for each vehicle.



Flat roof rack no accessories



Roof rack with half rail



Roof rack with full rail



Rack with spare wheel carrier Part-Nr.: 36-800950
Eye bolt 6 mm Part-Nr.: 36-800960
Eye bolt 8 mm Part-Nr.: 36-800959



Water tank 57 l with belt system Part-Nr.: 36-800961
Jerry can holder for 2 can Part-Nr.: 36-800951
Jerry can holder for 1 can (not shown) Part-Nr.: 36-800952
Canoe holder Part-Nr.: 36-800971



Gas bottle holder Part-Nr.: 36-800954
Pair of belt system Part-Nr.: 36-800958
Spade Part-Nr.: 36-800949
Spade adapter Part-Nr.: 36-800953
Hi-Lift adapter (no Hi-Lift) Part-Nr.: 36-800955

Fixing to the vehicle roof is specific, but the 4 foot kits shown are the most commonly used systems



Rail system, which has to be mounted first on the vehicle roof (drilling is necessary).



Clamping system for existing reeling systems (check the manufacturers max roof load).



Fixed mount on a specific vehicle manufacturer fitting point.



Fitting system for the rain gutter on the vehicle.

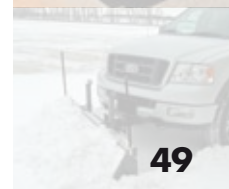
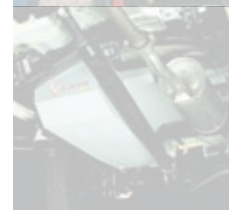
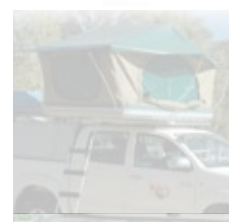
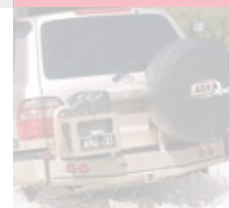



Foldable universal ladder, lays against the wheel.
Easy access to your roof rack (roof tent)
Part-Nr.: 36-800956



Shower cabin, Part-Nr.: 36-800957



Special awning, no ground support needed **size:** 180 x 280 cm – only available for racks 200 cm long and over.
Part-Nr.: 36-800977



The **camping table** is cleverly stored with a rail system under the roof rack.

camping table

(stainless) size 118 x 75 cm

Part-Nr.: 36-800962

Rail kit for the table

Part-Nr.: 36-800963

This system is simple and well priced.
Any accessory including a bigger roof tent can be mounted without drilling into this rack. The rail system allows you to slide in bolts or nuts wherever you want. The vehicle specific foot kit has to be ordered separately. The aluminium profile comes in standard width of 146 cm.
Part-Nr.: 36-871480



TechniTop Roof Tent

This state of the art rooftop is made in South Africa and can be used with most roof rack systems. This tent is made in a folding flat building method.

These tents are made in a strong polyethylene case, which functions as the floor of the tent. The floor is 45 mm thick and hollow inside. This gives an enormous torsion strength and a very good isolation against the cold weather. Even a night with freezing temperatures is not a problem. The framework, from lightweight aluminium together with the high quality Riblock Acrylic Dralon secure a dry sleep in rainy conditions. Extendable interior poles allow the doors to overhang the tent base and give first class rain drainage. The Technitop has an adjustable PVC flysheet to adjust the airflow between the inner and outer tent for extra ventilation.

The standard ladder has wide steps for better comfort. The tent is built up in minutes. The mattress is 50 mm thick and has a washable cover and the bottom is rubber coated. The lightweight steel frame contained in the floor gives a strong support to the hinging mechanism and the fitting to the roof rack.

Part-Nr.: 32-85000

Measurement:

Length closed: 110 cm
 Length open: 220 cm
 Width: 130 cm
 Height: 28 cm
 Weight: 52 kg



shown with optional extension tent

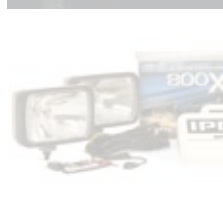
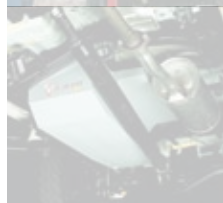

NAPIER EXTENSION TENT



← NAPIER extension tent for off-road vehicles and SUVs

For all those who enjoy spending nights out in the open with their off-roaders or SUVs, Taubenreuther has included the SPORTZ SUV tent in its steadily growing programme for camping and leisure time accessories. The three-by-three metre size tent has a headroom of approx 210 cm and can be simply attached with lashing straps to the rear of most SUVs and off-road vehicles. With the tailgate opened this creates a space for sleeping, eating, etc. that is protected from wind, water and observation. A double-layered floor provides additional protection against moisture from underneath. And when the vehicle is being used the SPORTZ SUV tent can also stand by itself, the opening to the vehicle being closed for this purpose.

Part-Nr.: 32-881000CMX

Technical data:

Floor area: 3 x 3 Meter / Internal height: ca. 2100 mm,

Water column: 2100 mm



This innovative tent wraps around the cargo area of your vehicle allowing you to access the interior for additional space. The attached screen room offers a 2,1 x 1,8 m area for bug free dining and family gathering. The 3 x 3 m tent provides a sleeping area for 5 to 6 people along with the additional space provided by your vehicle.

Part-Nr.: 32-883000

Technical data:

Floor area: 3 x 3 Meter / Internal height: ca. 2200 mm

Water column: 1200 mm

Weight: 15 kg



Two-man tent with full rain fly, size 2450 x 2100 mm, incl. 2 Thermolite sleeping bags (-4°) and 2 stools which all pack in a strong carrying bag 55 x 30 x 27 cm. Complete weight: 10 kg perfect for ATV's or motorbikes.

Part-Nr.: 32-895400

Advice:

We recommend to seal all seams with a standard style sealant for synthetic fabrics before the first use.



ARB Roof Console

Now you have a new solution for your CB/ Navigation system ... or whatever!
Especially for newer vehicles that have 2 air-bags and limit the possibility to install the extras that you want.

Our solution:

A new ARB roof console that fits between the front and rear seats offering 3 different areas to place additional equipment. Pre-wired with integral lighting and covers for unused sections. The console is delivered with all bracketry for fitment into existant fitting points in most vehicles.

- 1 Hidden lights, pre-wired, with switch
- 2 Opens downwards for storage area (180 x 65 x 200 mm)
- 3 Plastic housing matching the interior look of the vehicle
- 4 Pre-wired interior and map reading lights with separate switch
- 5 Side hole for radio (180 x 56 x 200 mm), accessible from both sides of the vehicle, covered



4Tcounter

Electronic distance counter and speedometer with 2 readouts for whole trip of specific part. Measuring any tire sizes for kilometers and miles. The full indicator reading can become manually preset. Both readouts can count forward or backwards with Freeze function. Connections for 2 master clocks, remote maintenance, foot switch, electronic storage of the data with power failure memory.

- Part-Nr.: 14-684001 4Tcounter distance counter
- Part-Nr.: 14-684002 Universal-inductive pickup
- Part-Nr.: 14-684003 Universal-master clock for electronic speedo
- Part-Nr.: 14-6840011 additional driver display option available

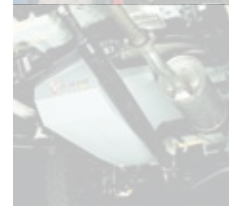
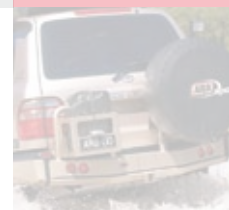

Storage System

Developed and used for over 20 years in the Australian Outback, the technology was transferred to a South African facility to offer reduced delivery times at a better cost. We now supply organisation systems for most 4WD vehicles. Ideal for globe trotters, tradesmen, charity workers and those who just want to be a little better organised! The drawers are solidly constructed in zinc-plated steel sheet and are covered with a rugged dark grey or brown material. Different combinations and sizes exist to meet a variety of uses. With a quality manufactured drawer rail system the bearings are built to withstand the toughest of uses for many years.

The drawers can hold up to 150 kg weight and the optional fridge platform holds 100 kg. The whole system is easily installed and can be extended to add optional equipment.

In most cases no extra drilling into the vehicle is necessary.

Options for a bed or a water tank are available



Rover Freelander



Toyota J100





VW T5



Toyota J120 (brown)



Jeep Cherokee KJ



Honda CRV



shown with optional watertank



Rover Discovery

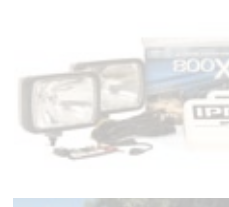
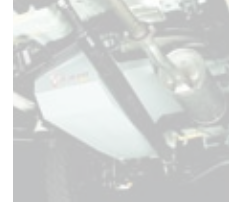
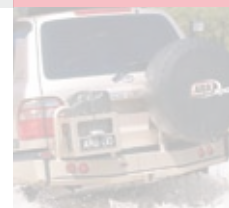

WAECO CoolFreeze Compressorbox

People who place a lot of value on excellent cooling facilities while on the road are well advised to get a CoolFreeze Compressorbox from WAECO. The cold is generated with the aid of a coolant that is driven around a circuit and through a compressor. **Suitable for solar operation.**

The result

- From standard +10 °C cooling to deep cooling at -18 °C
- Excellent cooling results even at extreme external temperatures
- Minimal consumption of energy
- Super-quiet running



Ergonomically shaped recessed grips and strong carrying handles that can be mounted (apart from the CF-25) ease the transport of these particularly light boxes



Standard: internal lighting (apart from the CF-18) for a better view when it's dark and super-easy cleaning with rear-foamed evaporators.



NEW: Digital display with CF special electronics



Designation	CF-18	CF-25	CF-35	CF-40	CF-50
Gross content	18 litres	23 litres (4 l stay-fresh)	31 litres (4,5 l stay-fresh)	37 litres (6 l stay-fresh)	49 litres (8 l stay-fresh)
Input voltage	12/24 DC	12/24 DC	12/24 V DC 100-240 V AC	12/24 V DC 100-240 V AC	12/24 V DC 100-240 V AC
Average power consumption	ca. 35 W	ca. 35 W	ca. 45 W	ca. 45 W	ca. 45 W
Temperature range	+10°C to -18°C	+10°C to -18°C	+10°C to -18°C	+10°C to -18°C	+10°C to -18°C
Dim. (W/H/D) in mm	465 x 414 x 300	550 x 425 x 260	580 x 385 x 360	580 x 445 x 360	630 x 480 x 360
Weight	11,5 kg	12,5 kg	15 kg	16 kg	18 kg
Part-Nr.:	18-CF-18	18-CF025DC	18-CF-35AC	18-CF-40AC	18-CF-50AC
High quality insulation and protection shells for CoolFreeze CF-18, CF-25, CF-35, CF-40 and CF-50					
Part-Nr.:	18-ICCF18	18-ICCF25	18-ICCF35	18-ICCF40	18-ICCF50



WAECO

Waeco is known around the world for its competence in mobil cooling technology and comfort products in auto electronics.

Both the Coofreeze compressor tool boxes DCF-25 and CF50 have the best technical compressor available today. These powerful boxes can work anywhere in the world with any electrical adaptor (the CF-25 needs a special adaptor).

For 12,24, 100 or 240 Volt – the new electronics recognise the voltage and automatically adjust. Easy to transport, just the right size. The comfortable to transport boxes are optimized in size. With the great volume the Coolfreeze boxes are ideal for Van's, 4 x 4, motorhomes and boots and ensure that food, drinks and even medicines stay cold. Drawers and other accessories also available.



WAECO SinePower

Sine-wave inverters generate a current similar to that of a mains socket and therefore suit any equipment, even the most sensitive. With the 150 and 350-watt units small items such as TV/sat units, DVDs, videos and computers can be operated without any problem. Whenever you are using large, sensitive and high power items of equipment, the large sine-wave inverters of 700 watts and upward should be used. These fulfil requirements in terms of a precise, microprocessor controlled output voltage, a high safety standard, light construction and a quiet load-dependent fan.

As an option the inverters can be operated conveniently via a radio remote control unit.

SP162



SP1000



Sine wave inverter	SP162	SP352	SP700	SP1000
Input voltage	10,5 - 15 V	10,5 - 15 V	10,5 - 15 V	10,5 - 15 V
Output voltage	230 V AC/50 Hz	230 V AC/50 Hz	230 V AC/50 Hz	230 V AC/50 Hz
Continuous rating	150 Watt	350 Watt	700 Watt	1000 Watt
Peak rating	300 Watt	700 Watt	1200 Watt	2000 Watt
Dimensions mm [W/H/D]	147 x 60 x 185	147 x 60 x 185	180 x 72 x 295	182 x 88 x 383
Voltage	12 V	12 V	12 V	12 V
Part-Nr.:	14-SP16212	14-SP35212	14-SP70012	14-SP100012

Radio remote control from the 700 watts version upwards. Part-Nr.: 14-MCR-6

WAECO PerfectPower

The proven inverters in the WAECO PerfectPower series generate a 230-volt alternating voltage from a 12-volt battery voltage. Because of their reliability they have been part of our customers' on-board equipment for many years. They are available in five rating variants, tailored to most current 230-volt items of equipment.

PP150



PP1000



Inverter	PP150	PP300	PP500	PP1000
Input voltage	10 - 15 V	10 - 15 V	10 - 15 V	11 - 15 V
Output voltage	210-230 V AC/50 Hz	210-230 V AC/50 Hz	210-230 V AC/50 Hz	210-230 V AC/50 Hz
Continuous rating	150 Watt	300 Watt	500 Watt	1000 Watt
Peak rating	300 Watt	600 Watt	1000 Watt	1600 Watt
Dimensions mm [W/H/D]	103 x 65 x 150	103 x 65 x 205	103 x 65 x 240	210 x 77 x 300
Voltage	12 V	12 V	12 V	12 V
Part-Nr.:	14-PP15012	14-PP30012	14-PP50012	14-PP100012

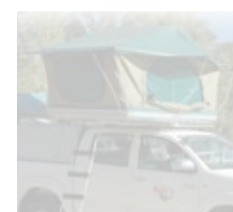
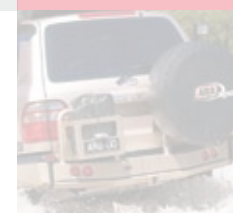

ENGEL-Fridges

ENGEL- a legend in reliability for many years

Engel coolers are highly regarded since decades - especially in areas where they are really put to the test. Their reliability, robust construction and their constant cooling power are their biggest selling points. Engel fridges that were made decades ago are still performing on the road keeping things cool.



The swing compressor

One of ENGEL's outstanding features is the Engel Swing Motor. The swing motor developed and manufactured by Sawafuji Electric Company, is an electro-dynamic reciprocating device that offers the advantages such as great economy, to resonance phenomena, low friction losses and minimum power consumption. Vibrations or 30° angles no problem it will function with optimal efficiency.

Countless tests have shown, that the ENGEL Swing compressor system works up to 50% longer with the same power supply as any competition. This new generation 2008 can work with any power and the change of power is controlled by an integrated 230 Volt priority function.

This new generation is again quieter and more energy efficient.





MT17F



MT27F



MT35F



MT45F



MT60F



MT80FS/FCS



Transitloks

Fitting kit for ENGEL fridges for secured transport and easy release function.



Transitbag

is made from tough material and gives extra isolation and protection to your ENGEL fridge.



Electric Connectors

Part-Nr.:	Size in mm	Capacity	Weight	Temperature Range	Power
18-MT17F	536 x 358 x 306	15 l	16 kg	+5° C to -18° C	32 W
18-MT27F	538 x 450 x 306	21 l	17 kg	+5° C to -12° C	32 W
18-MT35D	647 x 408 x 364	32 l	21 kg	+5° C to -18° C	32 W
18-MT45F	647 x 508 x 364	40 l	24 kg	+5° C to -18° C	32 W
18-MT60F	790 x 441 x 490	60 l	32 kg	+5° C to -18° C	52 W
18-MT80FS	790 x 561 x 490	80 l	39 kg	+5° C to -18° C	52 W
18-MT80FCS	Normal cooling but deeper capacity (data as for MT80FS)				

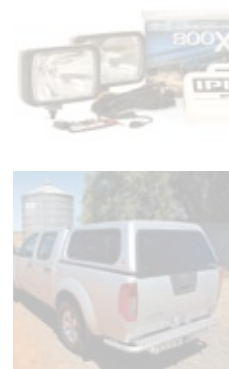
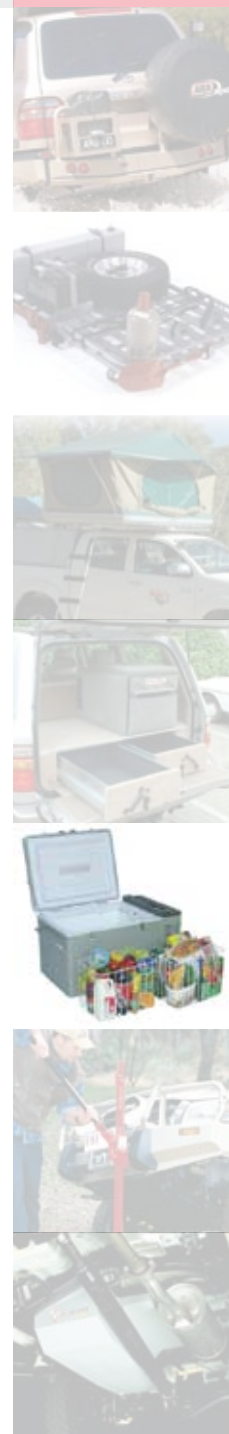

„Hi-Lift“ deLuxe

The Hi-Lift designed to be durable, adaptable and reliable, for use with your 4x4 at work and play, lifting, pulling and clamping just some of

1	Description	Hi-Lift 120	Hi-Lift 150
	Part-Nr.:	15-9998	15-99980
	Weight:	12,77 kg	14,20 kg
	Width:	12,70 cm	12,70 cm
	Height:	128,90 cm	156,85 cm
	Depth:	24,46 cm	24,46 cm
	Capacity:	3175 kg	3175 kg
	Max Lift Height	98,12 cm	126,37 cm

the tasks you can put the jack to, and with accessories available to make it even more adaptable and mountings to stow it safely

2 **NEW! Xtreme Jack:**

4ft & 5ft Xtreme Jack. Top of the range, all cast with special features including charcoal metallic powder-coat finish, gold zinc-coated hardware & handle, and a special top winch-clamp spreader attachment.

Part-Nr.: 15-9998XT-120

Part-Nr.: 15-99980XT-150



Hi-Lift Jack Mount for ARB Bumperbar
Part-Nr.: 15-9999



Bumper Lift designed to fit curved bumpers
Part-Nr.: 15-99990



Universal bracket
Part-Nr.: 15-99994



Hi-Lift adapter for wheels
Part-Nr.: 36-800970



Universal Rifle Holder

The new, improved universal rifle holder with room for 2 rifles. Due to the adjustable mounting parts it can be attached almost anywhere.

Part-Nr.: 15-310



Hi-Lift adapter for ARB roof racks

Part-Nr.: 2-66202

Part-Nr.: 2-66203 for Toyota J100



Axle Stand supporting block

It can be a bad feeling when you have broken down or are doing repair work under a vehicle not knowing how securely the car is jacked up. With the axle stand from African Outback there is added security. After the car has been raised using the jack or Hi-Lift, simply put the folding axle stand under the axle and your car is safely held off the ground. This Supporting block can be adjusted to different heights to work on an SUV as well as on a 4x4.

Folded, it takes up only minimum space.
Part-Nr.: 36-800973



Hi-Lift Jack Plate

The practical addition of the Axle Stand. The Hi-Lift can also be used on loose and muddy ground. It can also be useful for other jacking equipment, due to identical basic dimensions as the Axle Stand both parts can be stowed with each other.

Part-Nr.: 36-800979



Tyrepliers kit

All travellers carry a spare tyre, but when bad luck strikes, it's essential you carry the necessary equipment to perform tyre repairs. We stock the quality range of Tyrepliers tyre changing and repair equipment. Tyre levers, bead breaker, and a puncture repair kit for tube and tubeless tyres are available as a kit, or can be purchased individually.

A mallet is also available separately.

Part-Nr.: 35-ARB100

Tyrepliers single

Part-Nr.: 35-ARB101

Tyrepliers, 2 x 600 mm plier and tire repair set in a bag

Part-Nr.: 35-ARB102,
600 mm plier single

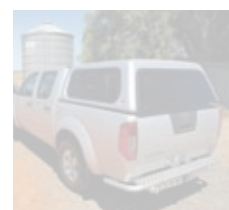
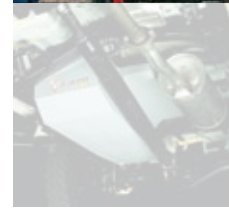
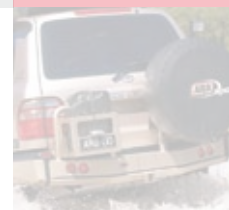

ARB Adventure Light

The 4x4 Adventure Light is a tough, compact and lightweight 12 volt flurescent light, suited to numerous outdoor activities. The light intensity is simply stunning, yet the Adventure Light draws a minuscule current of just one amp. The light will operate from a standard 12 volt power socket in your vehicle, or a portable battery pack. It comes with a 5 metre power lead incorporating an in line switch, dual hanging points and is supplied in a durable canvas storage bag.

Part-Nr.: 35-ARB225

holder for 35 mm tube (ARB roof racks)

Part-Nr.: 35-ARB225H



ARB universal attachment system

ARB has introduced a universal attachment system. In principle the idea is not new, but problems with loads sliding around still continue to occur, as for example on the loading platform of pickups, or when on expedition. The ARB system consists of 1.2 metre long rails, which can be shortened to the length required – as an alternative there are also short 4.5 cm mounting plates.

These are bolted to the loading platform and so serve as attachment points for the loading eyes, which can be easily attached to them using quick release fasteners. Two mounting plates and two loading eyes can also be obtained as a particularly cost-effective kit. With the correct ratchet straps – which are available in various designs – any attachment problem on the vehicle can now be solved.

Part-Nr.: 35-LT01 1 Attachment rail, length 120 cm

Part-Nr.: 35-LT02 2 Mounting plates, each 4.5 cm long

Part-Nr.: 35-LR01 2 Loading eyes

Part-Nr.: 35-LK01 Kit consisting of 2 mounting plates and 2 loading eyes

Part-Nr.: 35-RT06 Ratchet strap with 2 J-hooks, 5 m x 50 mm, 1,000 kg

Part-Nr.: 35-RT08 Ratchet strap with 2 J-hooks, 4 m x 35 mm, 1,000 kg

Part-Nr.: 35-RT11 Ratchet strap with 2 J-hooks, 3 m x 25 mm, 750 kg



Replacement Fuel Tanks

Another great product from Australia! Long Ranger replacement fuel tanks were developed especially for the long roads in the Australian outback where petrol stations are few and far between. They also have advantages for more urban use:

- increase the vehicle's travel range
 - save time as you do not have to stop and fill the car
 - you can fill up your tank wherever the fuel is cheaper
- 1 year guarantee

Every Long Ranger replacement fuel tank is manufactured according to the highest technical standards. Before painting, each tank is separately pressure checked. Due to the special design fuel movement is reduced to a minimum. Replacing your tank with a Long Ranger fuel tank has hardly any effect on your vehicle's abilities. The tanks are manufactured using 2 mm steel, which is painted with a grey coating. Almost all tanks are filled through the vehicle's original filler neck.



Nissan Patrol GR



Toyota Hilux



Fitted to Landrover Defender 110

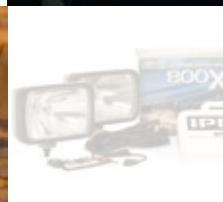
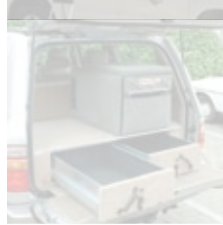



Safari Snorkel

The SAFARI Snorkel is designed to raise your air intake as essential insurance against the engine ingesting water or dust, and providing the clean cool air your engine needs to perform, with possibly improved fuel efficiency. SAFARI complements your vehicle's look, its black aerodynamic shape helps to reduce the possibility of air stream noise, with little or no effect on drivers vision. For extreme conditions the standard Air Ram can be replaced with Pre Cleaner.

Features:

- UV stable crosslinked polyethylene body for the ultimate in strength
- High flow air ducting & body ensures air supply in excess of engine requirements
- Each component is designed for maximum dust & water sealing
- Stainless steel & plated hardware for corrosion resistance
- Unique evacuation system effectively disperses rain and unwanted moisture
- Completely Australian designed & manufactured

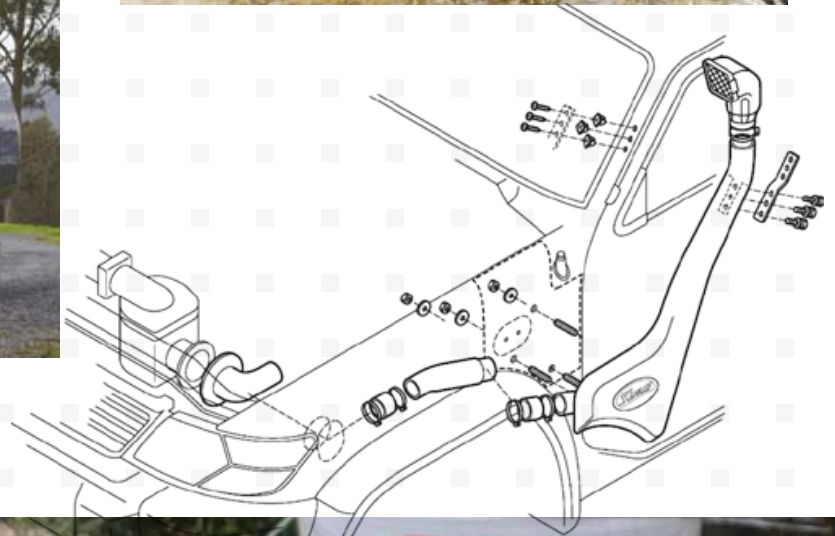

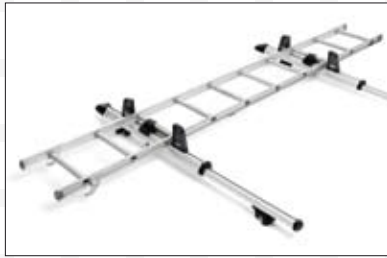

Thule Ladder Tilt the innovative Thule Ladder Tilt with a unique extender function is designed to work with you, tilting down to an ergonomic height that will save your backs as well as the paintwork of the car.



Fold Down Load Stop
This innovative, patented load stop keeps your load firmly in place and prevents it from sliding.



Thule Ladder Holder
It features a unique fastening solution based on robust straps with a ratchet mechanism for quick and easy loading and unloading.



Thule Conduit Box
The double openings at the front and rear ensure easy access to the load, while slam locks provide reliable theft protection. Perfectly ideal for quick, secure and efficient storage of piping.



Easy Acces – With double openings. Accessory 318 including a mid wall and a wire trace allows you to separate short and long pipes. And makes it easy to get shorter items out.



Thule Roller This Roller makes it easy to slide longer objects onto the load carrier. The risk of damaging the car roof or the back of the person doing the loading is greatly decreased.



Designed with a purpose for professionals like you

The Thule Professional load carrier system is a unique solution designed specifically for the really tough demands of on-the-move professional. Now you can take advantage of this rugged, fully integrated system to help make every workday easier, safer and more productive.





AGM Batteries

AGM batteries from Mastervolt can be used as starter or service batteries, are extremely long life, service free and can be installed anywhere. No special housings or ventilation needed as natural ventilation is adequate. They can work in hot or cold conditions. A great alternative battery when Optima isn't powerful enough or doesn't fit.

Model	AGM 12/55	AGM 12/70	AGM 12/90	AGM 12/130	AGM 12/160	AGM 12/225	AGM 12/270
Cold cranking amps (CCA)	-	617 A	885 A	-	1518 A	1980 A	-
Voltage	12 V	12 V	12 V	12 V	12 V	12 V	12 V
Capacity	55 Ah	70 Ah	90 Ah	130 Ah	160 Ah	225 Ah	270 Ah
Weight	14,7 kg	22,2 kg	30 kg	Please inquire	43 kg	64 kg	Please inquire
Size (L x B x H mm)	255x130x210	348x167x181	330x173x237	Please inquire	485x177x242	522x240x241	Please inquire

IBS Dual Battery System

A very good example that a proven and trouble free product can be improved. The new version of the DBS BM3 is controlled by a micro processor and an acoustic signal warning from low amps in the batteries. The new included solenoid is now good for constant 200 A and up to 500 A top load with different adapters for the monitor and the triple battery system TBS. Now comes with a 5 year manufacturer's warranty.

The DBS BM3 is simple to mount and is a powerful double Battery system, the development was made with extreme 4x4 use in mind as well as expeditions and for race vehicles.

As soon as the generator delivers power activates the battery monitor the solenoid over which can be loaded up to 3 extra batteries. As soon as the power is gone activates the battery monitor and the solenoid can be loaded with up to 3 extra batteries. The system automatically recognises when the power is switched off and disconnects the battery from the circuit. When a lot of electric power is needed for example with a winch or starting the engine in freezing temperatures - then the external battery can be manually operated to help the starter battery. On the on board monitor you can see the current Voltage of any single battery and you are able to check the reloading. If you don't want the display information then opt for the cheaper version, the DBI.



OPTIMA-Batteries

With the unique SpiralCell®-technology, Optima combines the advantages of several battery constructions that offroaders have dreamed of. High cold start capacity in order to start high volume motors, high current output for users of winches and alternating-current converters of 220 V, absolutely shock resistant, good deep cycling and absolute guarantee against leaking even in extreme conditions; and this in a compact construction to allow the installation of a second battery. The Optima has a very low inherent resistance and therefore high charging electricity can be stored and delivered quickly. No special charger is required for the OPTIMA-battery but an overload device should be installed.

How do you choose the correct battery?

The cold cranking amps (CCA) which indicate the power needed to start the engine when it is extremely cold. A standard 88 Ah battery of conventional construction has an average of 680 CCA and can be substituted by an OPTIMA RED TOP 4,2 LU with 815 CCA when its only task is to start the motor.

To say it differently: to reach the 815 CCA of the OPTIMA RED TOP 4,2 LU, a conventional battery of a freight vehicle with 155 Ah is necessary.

What information gives the capacity? It is the content of the battery, the electricity that can be used without needing to refill the battery. Theoretically, 88 Ah means that 1 A will be supplied for 88 hours or that 88 A will be supplied for 1 hour. In reality, those ideal conditions are hardly encountered, that is why one has to work with values experienced. If more current is needed than can be supplied by the alternator or if electricity is needed when the engine is not running, then the capacity of the battery is an important criteria of choice. It would be wise to select a bigger battery or to choose a dual battery system. If electricity should be provided until literally "the lights are switched off", the right choice would be OPTIMA YELLOW TOP traction battery because of its good capacity of deep cycling.

Solid cast cell connections for increased durability

Pressure relief valves

Impact resistant polypropylene case

High-Purity lead grids provide longer life

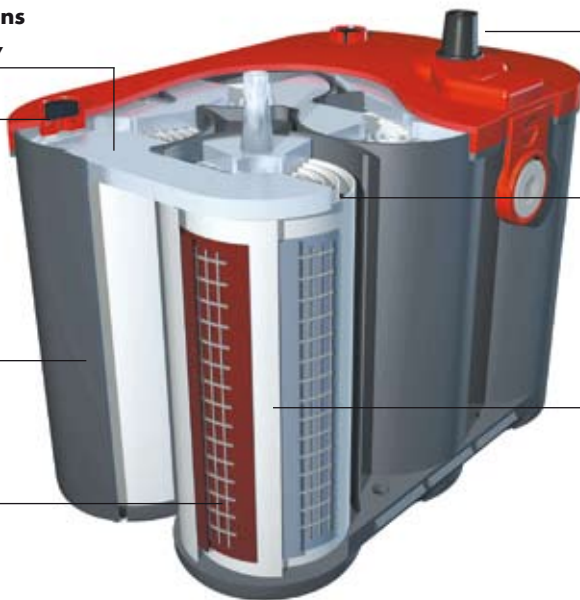

Corrosion resistant terminals

Rugged SpiralCell construction provides superior vibration resistance and higher power

Absorbent glass separator holds electrolyte like a sponge



OPTIMA RED TOP 4,2 LU

Part-Nr.: 14-88500
Cold cranking amps: 815 CCA
Capacity: 50 Ah
Size l x w x h: 254 x 175 x 173 mm
Weight: 17,6 kg
Poles: 2 DIN-Pole
2 Pole 3/8-16 UNC-2B



OPTIMA YELLOW TOP 4,2 LU

Part-Nr.: 14-87500
Cold cranking amps: 690 CCA
Capacity: 55 Ah
Size l x w x h: 254 x 175 x 173 mm
Weight: 19,9 kg
Poles: 2 DIN-Pole
2 Pole 3/8-16 UNC-2B

Used Batteries can be returned to sender and recycling is free of charge. The deposit is part of the sales price.



IPF Driving Lights

- Available in spot or driving beam
- Tough, heavy gauge steel body
- Submersible to 300 mm for up to 2 minutes
- Advanced heatproof resin reflector, incorporating water and dust resistant breather
- Reflector surface and bulb designed for ultimate performance
- Hardened glass lens
- Advanced IPF 65W H9 halogen bulb with water and dust seal for maximum life and performance
- Reinforced multi directional mounting system
- Waterproof connectors on bulb lead and loom connection Supplied as a kit



Complete kit includes:

- 2 Lights
- Complete snap together wiring loom & relay
- Mouse style LED switch
- White protective covers



Part-Nr.: 2-900XSDD



Part-Nr.: 2-800XSDD



Part-Nr.: 2-900XSHD



Part-Nr.: 2-800XSHD





SIRENA Swivel Light
for solid mount or with magnet plate.
Part-Nr.: 18-83152



SIRENA Swivel Light
for depth light mounted on 24 mm socket. DIN 72591



Remote Control with bracket
and 2 m cable, or remote control.

SIRENA Swivel Light Beam

Gives you light wherever you need it. This light was developed for rescue, fire, agriculture and work trucks. The operator can command the beacon to make a complete horizontal rotation and a vertical rotation, including upwards and downwards, at approx 260° the movement is guaranteed by two gear motors. You can choose between diffused light or depth light. The swivel light can be controlled by radio or cable. The advantage of the remote control is that it is possible to readjust the light when you are maybe on the end of your winch cable and need it there. When you switch off your light the beam automatically goes back into the vertical position. Available in 3 different sizes, 130 mm diameter to mount on socket DIN 72591, 130 mm for solid mount or with the magnet plate. The 200 mm version is only available as solid mount. All models can be supplied in 12 or 24 Volt, 55 W H3 bulbs coming with 130 mm version and the 200 mm comes with 100 W H3. The 130 mm SIRENA can be ordered as a video camera instead of the swivel light. We can also supply all accessories and products from the SIRENA product line.



Magnet Plate
with 2,5 m cable, tested max 150 km/h.
Part-Nr.: 18-83152

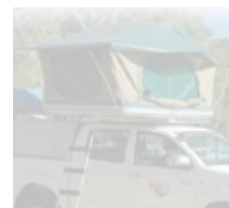
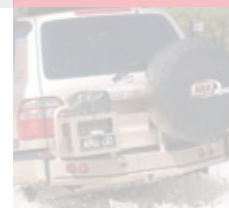

Smartop II

The cover that hides it all! Manufactured from aluminium extrusions with checker-plate top that comes complete with top railing to secure extra goods.

Lockable with electric release from inside the vehicle, also features a lid-light activated by an OE boot-lock securing all your valuables.

The Smartop is easy to install and user-friendly. By increasing the pressure of the two gas struts, even a roof-top tent can be easily lifted.

Several bikes can also be mounted by means of our bike bracket.

The entire unit is acid treated, powder-coated and clear coated which makes colour-matching an easy option. The Outback Smartop is available for all Double Cab vehicles. Load capacity max 250kg.



max opening angle (completely open)



New mounting position for the gas struts



Detail: Rail system with cross carrier



Smartop II: Rail system with cross carrier

Tonneau covers for the Toyota Hilux and Isuzu D-Max

In our part of the world it is necessary to protect vulnerable goods in pickup beds from the vicissitudes of the weather – and also to keep them out of the sight of prying eyes.

The new tonneau cover from Aero fulfils both these requirements, and has been produced to be totally compatible with the Toyota Hilux (Dual Cab and XtraCab) and also the Isuzu D-Max (Dual Cab and Space Cab).

The lockable GRP component can also be installed very simply – in conjunction with a bedliner – even without any drilling. It can also be painted to match the colour of the truck.

Part-Nr.:	Vehicle model
6-95001	Toyota Hilux Dual Cab
6-95002	Toyota Hilux Xtra Cab
6-95003	Isuzu D-Max Dual Cab
6-95004	Isuzu D-Max Space Cab
6-95005	Mitsubishi Dual Cab, '06
6-95006	Mitsubishi Clubcab, '06

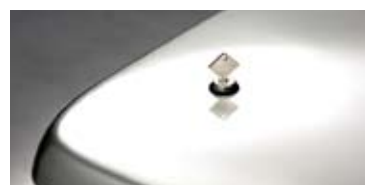

Aeroflex tonneau cover:

Material:	GRP honeycomb construction, unpainted, internal surface clad with carpet
Weight:	33 kg
Opening angle:	45° via two shock absorbers
Installation time:	approx. 1 hour, no drilling necessary!
Removal:	approx. 2 minutes
Load capacity:	50 kg
Lock:	lockable latches on the left and right-hand sides
Seal:	running around the periphery
Prerequisite:	bedliner

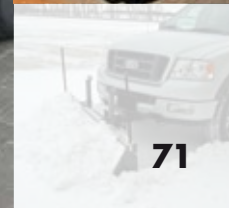
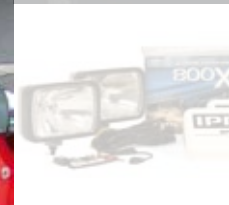
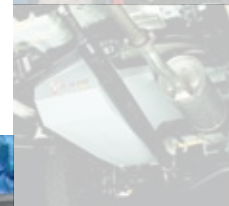
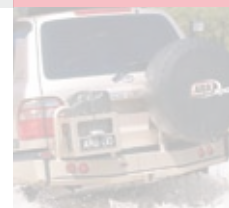



The Aero bedliner family is the optimum for your truck.

These bedliners are made using aluminium molds for a quality fit and a constant material thickness and the result is a perfect fit. The high quality polyethylene is made in AERO's own factory to get a constant quality in raw material. The program range includes the newest Asian trucks like the Nissan Navara (D40) or the new Hilux and the newest

Mitsubishi (L200). For the older models we will keep stock – some of the older models we will only supply as Hero Liner, made to the same standards but the base material is 1 mm thinner.



The chromed "Army Hook" secures your load from sliding.



Innovative no-drill installation.



The optional AERO load stopper comes in a kit of 4 units.



The liner tape gives superior protection from scratches in the rub zone between the liner and the vehicle paint.

New! The storage master

The request for storage boxes for the pick up bed is high – the quality of good suppliers is small. We have searched for a long time to get the right product and with AERO we have a big and strong manufacturer at our side. Together with the high quality bedliner, this product has a perfect look and fit. This box is manufactured in high quality polyethylene and is available in 2 sizes. A small storage compartment is standard and can be removed.



New: For older Pick up modells Taubenreuther offer Aero bedliners!

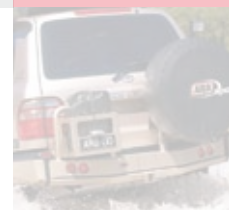

News 2008/2009



What cab form does your vehicle have?

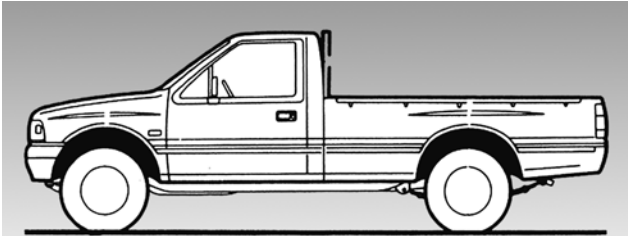

Single-Cab

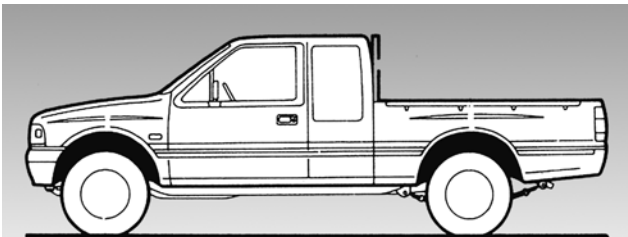

King-, X-tra-, Sports-, and Space-Cab

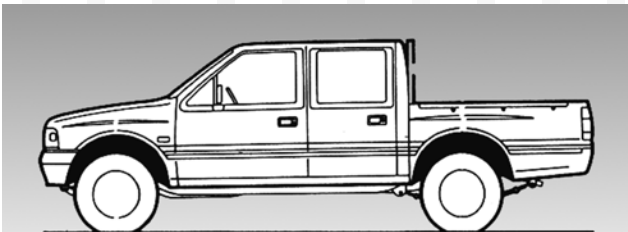

Double-Cab

What is the difference between ABS and Fibreglass?

ABS (**A**crylonitrile **B**utadiene **S**tyrene) is a synthetic tetrapolymer, a thermoplastic material. The shell is thermally formed, it is extremely strong but lightweight and formed in one piece.

Fibreglass is a glass reinforced laminate - **Polyesterene**, **Epoxyresin** or **Polyamide** and is

- heavier than ABS
- poor in fluctuating temperatures
- not recyclable
- easier to produce - so it is possible to produce in small series

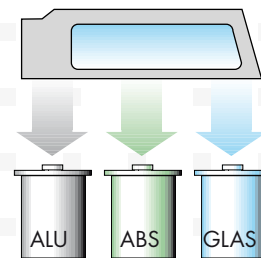

Our Hardtops are 99,9 % recyclable. The main components are plastic, glass and aluminium.

No problem to put them into the recycling stream.



The Top of the tops!



- ABS shell with limited life-time warranty, especially for off-road use
- 100 % recyclable ABS



- Custom paint, optional at extra cost



- Option: with side sliding window - lift up side window
- To combine with a bedliner



- Packed for easy transport



Without side window



With side window

Interior dome light standard

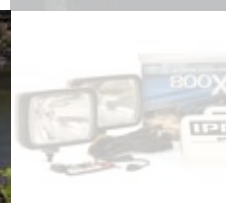
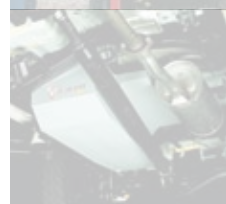

What you should look for when you buy a Hard top

Firstly, why do you need it?

For commercial use we recommend without side windows to protect your belongings from prying eyes. For extra ventilation use a front sliding window – for example when carrying your furry friends! We also supply replacement sliding windows for your truck cab to allow access to the bed from the truck cab. As a multifunctional family vehicle your pick up is enhanced with a top which protects your belongings from the elements. The side sliding windows give both functionality and enhance the design of the top. We are flexible to custom tailor your top to best suit your needs.



Roof rack over Nissan Navara



Thule roof rack over ARB Top





Toyota Hilux, 05 Double-Cab high



Mitsubishi L200, 06 Double-Cab flat



Ford Ranger, 06 Double-Cab high



Nissan Navara King Cab with side windows



Toyota Hilux, 05 Double-Cab high



Ford Ranger Double-Cab, 06 flat



Front safety grill (optional)



Side window safety grill (optional)

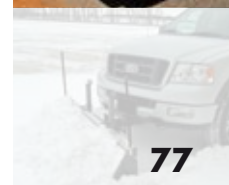
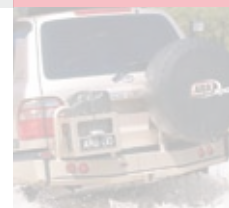



Sliding window

Fast and easy mounting for easy access to truck bed.
Works well with all hardtops with front sliding window option.



Air Gate

Give your Pickup that sporty look with the advantage of saving fuel, the holes reduce air resistance. Quick connectors make for an easy installation available in black.

Part-Nr.: 18-9071 – 1230 mm

Part-Nr.: 18-9023 – 1380 mm

Part-Nr.: 18-9007 – 1500 mm

WORKS Powermate

The new useful tool for hunters, landscapers, outdoor workers etc., who need to load large items into medium or larger pick-ups.

The frame adjusts width-wise between 1m40 and 1m80, adaptable to most vehicles.

The kit comes complete with a winch, solenoid, distance cable control, 15 x 15 steel cable, spooling device and roller fairlead.

Ideal for pulling up to 500 kg – for ATVs, motorbikes, lawn mowers and such like.

Part-Nr.: 1-39043, **without** winch

Part-Nr.: 1-390430, **with** Works 1700





Slider for pick up bed

With this accessory you can easy load and unload your goods from the pick up bed especially with mounted hardtop.

Part-Nr.: 36-70000 (1360 x 1040 mm)

Part-Nr.: 36-70001 (1500 x 1040 mm)



Dog Boxes

Adjustable iron cage dog box for mounting under a hard top. With this system you can safely transport two dogs in separate boxes - or one dog and other goods. It is a three piece system and variable in length and width. The additional door in the box allows you to open the rear door in the hard top and the dog is safely in the car with more fresh air.

It is a three-piece-system and variable in length and wide. The additional door in the box allows to open the rear door in the hard top and the dog is safe in the car in fresh air.

Part-Nr.: 15-35000

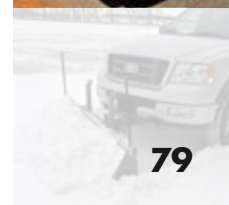
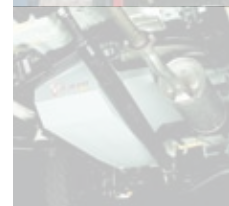
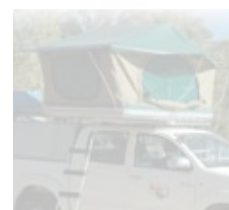
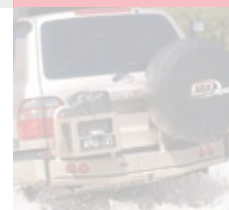



SNOWWAY

The SnoWay plough system has been on the market for 25 years and since then Taubenreuther GmbH has imported it into Europe. The development of the product has been a continuing process.

The features of this product are:

- built with high strength steel components
- low drag polycarbonate blade skins
- super fast hydraulic system
- hydraulic system on the plow
- easy to service hydraulic system
- smart mounting system for easy on and off
- low cost when you change the vehicle and keep the plow
- full range of accessories
- 30° angle to left and right
- the lightest plow system in the class

The highlight is the patented SnoWay Down Pressure (DP) system which gives a superior scraping and back dragging.

SnoWay series 22 (DP) Hydraulic Snow Plow

Part-Nr.:	snow plow width/height	total-weight	30° angle plowing width
5-822183	183 x 55 cm	130 kg	161 cm
5-822203	203 x 55 cm	135 kg	178 cm
5-822229	229 x 55 cm	147 kg	196 cm





SnoWay 100 l Spread specification

capacity	100 l
size	65/96/85 cm
spread width	1 - 8 m
spread	Salt
motor	12 V electric
Part-Nr.:	5-99100835
on/off switch	5-99100531
variable speed dial	5-99100498

New compact spreader from SnoWay

The all new 100 l capacity salt spreader from SnoWay is the ultimate de-icing solution for small truck and SUV applications.

Sealed electric motor mounted separately from the hopper and isolated from the elements.

This patent pending feature keeps the motor separated from the hopper interior and away from salt.

The motor components are also specially coated to eliminate corrosion.

Enclosed motor assembly located under top cover.

Exclusive chunk buster™ design inside hopper.

The spinner drive shaft contains protruding bolts that break up salt clusters before spreading.

The design keeps salt flowing uniformly and prevents clogging.

Adjustable flow paddle & roller wheel portability.

The lockable paddle can be adjusted to shut off spread material completely or fully opened for maximum flow. Impact resistant roller wheels make portability a snap in all conditions.

Built-in handles on either side & top of the spreader.

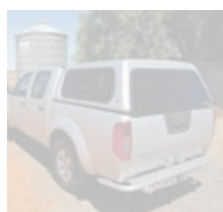
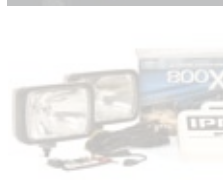
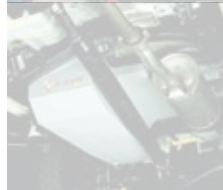
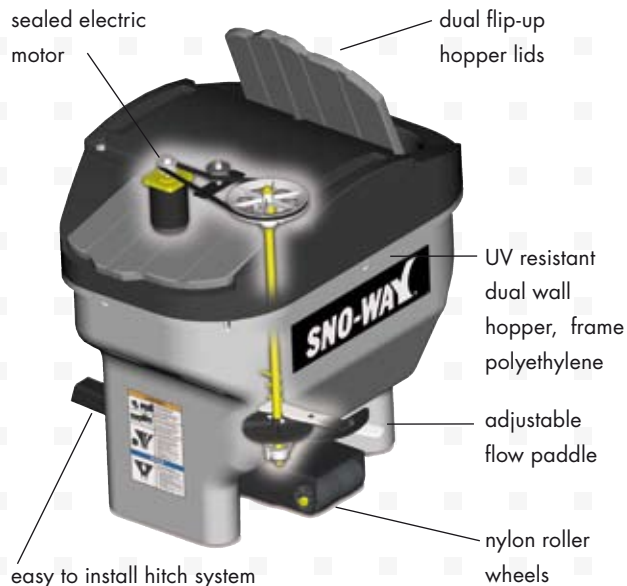

Please ask for special brochures!

Our current goal is updating our information platform on the internet. Of course you can use the existing one until the new pages are working and you can still place your orders as usual.

In the near future we will have more up to date information on the internet and new products will bring more life into this very interesting medium. The order system will be improved and the selection of pictures will be much wider. The advantage of the internet is the fact that information is more accurate than in a printed catalogue – when it is updated regularly and we will do our best.

In our service column, we will give maintenance advice and parts availability. The links to our national and international suppliers and dealers will be constantly updated. We will keep you posted on sports events and exhibitions.

We will do our best and look forward to making this new site live and look forward to your comments. Until it is finished have fun on our old site:

www.offroad24.com

Your Taubenreuther-Team



Please ask for special brochures on:

ATV-Accessories



Industrial Winches



WORKS Winches



Snow Plows



Austria**TAUBENREUTHER Ges. mbH**

Landstraße 18
5102 Anthering bei Salzburg
Tel.: (0043) 6223-20390-0
Fax: (0043) 6223-20390-20
verkauf@taubenreuther.at
www.taubenreuther.at

Polska**Trasek**

ul. Strowiejska 65/67
80-534 Gdansk
Tel. 058 3421575
info@trasek.com.pl

Italy**4 Technique S.r.l.**

Via Germania 19/21
41100 Modena
Tel.: (0039) 059451661
Fax: (0039) 059451653
www.4technique.it
info@4technique.it

Slovenia**Off Road Center Mamut****Mamut 4x4 d.o.o.**

Liparjeva 60
1234 Menges
Tel.: (00386) 01-7291353
Fax: (00386) 01-7291354
www.mamut4x4.com
mamut@siol.net

Spain**Tot Racing S.L.**

Pol. Les Goules
C/. Metal-Lurgia, 1
08551 Tona
Tel. 0034-93-5708182
4x4virtual@4x4virtual.com

Portugal**TAUBENREUTHER**

Rua Manuel Assunção Falcão, 212
4475-041 Santa Maria de Avioso
Tel.: (00351) 229872034/5
Fax: (00351) 229872036
taubenreuther.portugal@taubenreuther.eu
www.offroad24.com

Hungary**TAUBENREUTHER Kft.**

2310, Komp u. 3.
Szigetszentmiklós-Lakihegy
Tel.: (0036) 24539-160
Fax: (0036) 24539-170
taubenreuther@vnet.hu

Romania**TAUBENREUTHER Romania S.R.L.**

Str. Ion Budai Deleanu. Nr.48
400474 Jud. Cluj, Mun. Cluj. Napoca
Tel. 0040-745939223
office@karpatentour.ro

Croatia**Zen Teren d.o.o.**

Ilica 341
HR-10000 Zagreb
Tel.: (00385) 1-3750 668
Fax: (00385) 1-3750 668
Mobil: (00385) 91-3750 780
www.zenteren.com
d.geras@zenteren.com

Belgium**ATRAXION BVBA**

Industrieweg 19
2630 Aartselaar
Tel. 0032-38708091
info@atraxion.com

Czech Republic**Dajbych s. r. o.**

Umlyna 26
32600 Pilsen
Tel.: (00420) 377223535
Fax: (00420) 377221877
www.dajbych.cz
offroad@dajbych.cz

Switzerland**CASTY OFF-ROAD****Casty Robert**

Hauptstrasse 6
7014 Trin
Tel.: (0041) 0816351169
Fax: (0041) 0816351661
www.castyoffroad.ch
castyoffroad@bluewin.ch

Belarus**Firma Vasiliy Kiselyov &****A. Alshevskiy**

Gerasimenko 80-82
Minsk, Belarus
Tel.: (00375) 172050144
Fax: (00375) 172519208
www.offroadtrading.com
club4x4@belsonet.net

Bulgaria**Unit Total Real EOOD**

St. Peterburg 75 blv.
4023 Plovdiv
Tel: (+359) 32 277 999
Fax: (+359) 32 277 990
Mob: (+359) 888 524330
www.offroad24.bg
info@offroad24.bg



TAUBENREUTHER

Germany:
TAUBENREUTHER GmbH
Am Schwimmbad 8
95326 Kulmbach
Tel. +49 92 21/95 62-0
Fax +49 92 21/95 62-22
Internet: www.taubenreuther.de
Email: verkauf@taubenreuther.de

England:
TAUBENREUTHER Ltd.
Unit 4 Phoenix Industrial Park
Freshfields Road
Harwich, Essex CO12 4EL
Tel.: +44 1255556622
Fax: +44 1255554222
sales@tbruk.net
www.tbruk.com

Dealer: